



Installation Manual RM648HE 48V Rectifier

Product Compliance



RoHS

Electromagnetic Compatibility Directive (EMC) 2014/30/EU

Copyright © NewMar 2022 All rights reserved.

Release Date: 01 MAR2022

Disclaimer: NewMar reserves the right to make changes to the information within this document without notice

Table of Contents

1	Admonishments	5
2	Safety	5
3	Receiving Instructions.....	5
3.1	Package Inspection.....	6
3.2	Equipment Inspection	6
3.3	Handling.....	6
3.4	Identification Labels	6
4	Scope.....	6
5	Principles of Operation	6
5.1	Introduction.....	6
5.2	Rectifier Operating Mode	7
5.3	Indicators	7
5.4	Power and Current Limit.....	8
5.5	Output Over-Voltage Shut Down	8
5.6	Input Over/Under Voltage Shut Down	8
5.7	Rectifier Soft Start and Inrush Current.....	8
5.8	Over Temperature Turn Down/Shutdown	8
5.9	Rectifier Fan Operation	8
5.10	Reverse Polarity Protection.....	9
5.11	Active Load Share.....	9
5.12	Fan Cooling.....	9
5.13	Serial Alarm and Control Interface	9
5.13.1	Voltage Control.....	9
5.13.2	Rectifier Alarm states	10
5.13.3	Rectifier Shutdown	10
5.13.4	Post-mate Connection	10
5.14	Interface - Rear Connector	10
6	Installation.....	11
6.1	General Warnings.....	11
6.2	Rectifier Shelf	11
6.3	AC Supply Surge Protection	11
6.4	Ventilation	11
6.5	Rectifier Addressing	12
7	Commissioning the Rectifier	12
8	Specifications.....	13
8.1	AC Input.....	13
8.2	DC Output.....	13
8.3	Environmental.....	14
8.4	Mechanical.....	14
8.5	Compliances	14
8.6	Maximum Output Power.....	15
9	Servicing	16

9.1	Troubleshooting	16
9.2	Fuses	16
9.2.1	Rectifier Input Fuse Curves.....	17
10	Legacy Systems.....	17
Appendix I Newmar Energy Standard Limited Warranty Policy.....		18
I.A	Warranty Exclusions and Restrictions.....	18
I.B	Battery Warranty.....	18
I.C	Initiating a Warranty Claim.....	18
I.D	Disclaimer	18
I.E	Remark	19

TABLE OF FIGURES

Figure 1: Maximum Operating Envelopes	8
Figure 2: Rear Connector Pin Descriptions	10
Figure 3: Maximum Output Power for 110V mode.....	15
Figure 4: Rectifier Input Fuse Curves.....	17

LIST OF TABLES

Table 1: Rectifier Fan Operation with No Load.....	9
Table 2: Rectifier Fan Operation with Full Load.....	9
Table 3: Rear Connector Pin Configuration.....	10

1 ADMONISHMENTS

The admonishments are the symbols and wording used in this manual to alert readers to specific dangers and instructions. The meanings of the various admonishments are explained as follows:

Warning = risk to life or personal injury and equipment damage

Caution = risk of equipment damage.



= risk of electrical shock potentially causing death or injury.



= alert of risk potentially causing death or injury.



= risk of burn injury from hot surfaces



= an alert that must be understood and undertaken.



= instruction of mandatory reading of product manual.



= restricted access area



= access for children prohibited.

2 SAFETY



All installation and maintenance must be carried out by suitably qualified personnel.



For your protection, the product manual should be read and thoroughly understood before unpacking, installing, and using the equipment.



The equipment is intended only for use in a restricted access area. This equipment is not suitable for use in locations where children are likely to be present.

3 RECEIVING INSTRUCTIONS

Newmar provides all equipment to the delivering carrier securely packed and in perfect condition. Upon acceptance of the package from Newmar, the delivering carrier assumes responsibility for its safe arrival. Once the equipment is received, it is the recipient's responsibility to document any damage the carrier may have inflicted, and to file the claim promptly and accurately.

NOTE: the period to make a claim against damage by a transport carrier can be short, a matter of days, and varies by transport method, the transport contract, and local laws.

3.1 Package Inspection

Examine the shipping crate or carton for any visible damage: punctures, dents, and any other signs of possible internal damage.

Describe any damage or shortage on the receiving documents and have the carrier sign their full name.

3.2 Equipment Inspection

Open the crate or carton and inspect the contents for damage. While unpacking, be careful not to discard any equipment, parts, or manuals. If any damage is detected, call the delivering carrier to determine the appropriate action. They may require an inspection.

IMPORTANT: Save all the shipping materials for the inspector to see.

After the inspection has been made, if damage has been found, contact Newmar. We will determine if the equipment should be returned to our plant for repair or if some other method would be more expeditious. If it is determined that the equipment should be returned to us, ask the delivering carrier to send the packages back at the delivering carrier's expense.

If repair is necessary, we will invoice you for the repair so that you may submit the bill to the delivering carrier with your claim forms.

It is your responsibility to file a claim with the delivering carrier. Failure to properly file a claim for shipping damages may void warranty service for any physical damages later reported for repair.

3.3 Handling

Handle the equipment with care. Do not drop or lean on front panel or connector. Keep away from moisture.

3.4 Identification Labels

Model number and serial number are clearly marked on all equipment. Please refer to these numbers in all correspondence with Newmar. Ideally provide a photograph of the product label for reference.

4 SCOPE

This manual covers essential information for the installing and commissioning of the Newmar rectifier module part number RM648HE.

5 PRINCIPLES OF OPERATION

5.1 Introduction

The RM648HE/RM848HE are telecommunications grade rectifiers with the following features:

- Hot pluggable
- Forced Air Cooled
- Thermally Protected
- Wide input AC Voltage
- Constant Power Output Limit
- Input/Output Voltage and Current Protected



- Active Load Sharing
- Serial alarm and control interface
- Microprocessor controlled



5.2 Rectifier Operating Mode

The RM648HE is a rectifier that operates on mains systems with 110VAC and 230VAC nominal voltages. The rectifier will automatically sense the input AC voltage and adjust the output accordingly. To switch modes that system will need to be de-energized and the AC voltage input changed.

5.3 Indicators



There are 3 LED indicators on the front panel that show the operational state of the rectifier.

-   This green LED indicates that mains power is connected to the unit and that the primary stages of the rectifier are operating.
- A flashing green LED indicates the rectifier is in power saving mode.
- Please refer to the SM3x Manual or EM4x manual as appropriate for detailed operation description of the power saving mode.

-   This yellow LED indicates a non-urgent alarm state within the rectifier. This could be caused by the following:

- Rectifier in output power/current limit
- Rectifier over temperature
- Fan failed
- Rectifier soft starting
- Temperature sense fail
- Brownout

This red LED indicates an urgent alarm state within the rectifier. This could be caused by the following:

-   
- Rectifier fail
 - AC input voltage is outside the operating range
 - Postmate open
 - Input fail
 - Auxiliary rail voltage fail
 - Over temperature

* Note the LED responses are hard coded in the power module and do not change. Alarm priority in the controller is user configurable and presents more alarms than those shown here. Alarm definition displayed in the controller may not match the list presented here.

** When bootloading all LEDs are on.

5.4 Power and Current Limit

The rectifier automatically limits its output as load demand reaches its maximum capacity. Figure 1 shows the maximum operating envelopes for the RM648HE.

Figure 1: Maximum Operating Envelopes

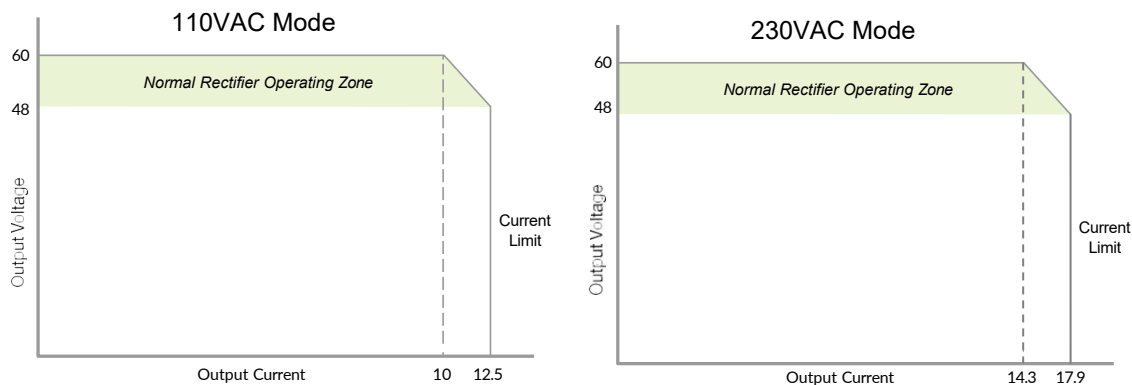

5.5 Output Over-Voltage Shut Down

The rectifier will automatically shut down if the output voltage exceeds the preset value. The Over Voltage Shut Down point reduces by about 0.5V at full load to ensure the rectifier producing the Over Voltage Shut Down turns off first. The Over Voltage Shutdown voltage is preset in the factory but may be adjusted.

5.6 Input Over/Under Voltage Shut Down

If the input voltage is outside the specified range, the rectifier may shut down until the voltage returns within the specified range.

5.7 Rectifier Soft Start and Inrush Current

On startup, the peak mains inrush current is limited to twice the maximum operating current. The output voltage and current will rise slowly from zero during start-up. This means that the AC input power slowly increases, the rate of which can vary, over a maximum of 6 seconds, providing a gentle load characteristic for any standby gear.

5.8 Over Temperature Turn Down/Shutdown

When the rectifier reaches its maximum operating temperature (internal), the rectifier will progressively reduce the output current to attempt to reduce the heat within the unit. The rectifier will continue to reduce the current till zero output should the temperature continue to rise. As the temperature decreases the rectifier will increase the output current till normal operational levels are reached.

The maximum ambient operating temperature range at full power is: -10 to 50°C.

The rectifier will operate in ambient temperatures up to 70°C but the rectifier will de-rate its output power to keep internal temperatures within the allowable range.

5.9 Rectifier Fan Operation

The rectifier fan operational behavior is detailed as follows.

Table 1: Rectifier Fan Operation with No Load

Internal Rectifier Temperature	Fan Operation
Below 45°C	15 second on minimum speed, 1 minute off
45°C - 50°C	15 second on minimum speed, 45 second off
50°C - 55°C	15 second on minimum speed, 30 second off
55°C - 60°C	15 second on minimum speed, 15 second off
60°C - 70°C	Continuously on, fan speed increasing up to maximum speed at 70°C

Table 2: Rectifier Fan Operation with Full Load

Internal Rectifier Temperature	Fan Operation
Below 25°C	15 second on minimum speed, 1 minute off
25°C - 30°C	15 second on minimum speed, 45 second off
30°C - 35°C	15 second on minimum speed, 30 second off
35°C - 40°C	15 second on minimum speed, 15 second off
40°C - 50°C	Continuously on, fan speed increasing up to maximum speed at 70°C

5.10 Reverse Polarity Protection

A crowbar diode is fitted to the back plane for protection in this state. If batteries are connected to the system with reverse polarity, the corresponding battery breaker will trip with no degradation to the rectifier system. The rectifier has no reverse polarity protection and relies on the protection provided by the backplane.

5.11 Active Load Share

The rectifier will actively current share with other rectifiers in the same DC system. The monitor control is used to make individual/separate racks share with each other.

5.12 Fan Cooling

The rectifier constantly monitors its internal temperature, ambient temperature, and output current, then adjusts fan speed to ensure continued operation. This control of fan speed ensures that rectifier acoustic noise and dust accumulation are minimized.

5.13 Serial Alarm and Control Interface

The rectifier, when installed in a Sentinel, is controlled via the serial interface by the system monitor. The system monitor can set up control parameters and receive alarm information via this interface.

If this interface is disconnected or fails for some reason the rectifier will operate with the parameters last sent from the monitor. Current share will revert to the rectifier current share bus.

5.13.1 Voltage Control

The rectifier voltages are set by the system monitor via the serial communications bus. The rectifier voltage can be set to any value between 43V and 60V.

Float Voltage Mode (AVC Off) The monitor sets the float voltage to its target level at start up, and then resends this same level at regular intervals thereafter. The voltage control is open loop.

Float Voltage Mode (AVC On) The monitor sets the system voltage to its target float voltage, then monitors the system voltage and adjusts rectifier voltages to maintain the system voltage at the desired float voltage.

Equalize Voltage Mode The monitor sets the system voltage to an elevated level (e.g., 56V) for a fixed period, and then resets the system voltage to the float voltage setting.

Fast Charge Mode The monitor sets the system voltage to an elevated level after a battery discharge. This keeps the rectifiers in current limit for a longer period, leading to a faster battery recharge. When the battery is recharged, the monitor resets the system voltage to the float voltage level.

5.13.2 Rectifier Alarm states

The rectifier will report the following states to the monitor via the serial communications:

AC Fail The AC supply is not present at the rectifier.

Rectifier Fail The rectifier is not functioning. This could be due to high output voltage, AC failure or a fault with the rectifier internally.

Over Temperature The internal temperature of the rectifier is too high and the rectifier has begun to limit its output to control this temperature.

Fan Fail The fan has ceased to work.

Current Limit The rectifier output has reached maximum, and the output current is being limited.

Shutdown The rectifier has been shut down by the monitor. It will restart again in 5 minutes unless the shutdown instruction is repeated.

EEPROM Fault The rectifier microprocessor has encountered an error while reading from EEPROM. **Soft Start** The rectifier has just turned on and is slowly increasing its output.

5.13.3 Rectifier Shutdown

The rectifier can be remotely forced to shut down, via the serial communications, by the system monitor and/or remote supervisory software. The rectifier will shut down for 5 minutes then restart. If a further shutdown signal is received by the rectifier before the 5 minutes is up, the timer will reset to 5 minutes. Hence, if a rectifier is to be kept shutdown a shutdown signal must be sent to it at regular intervals.

5.13.4 Post-mate Connection

The rectifier is “hot plug” capable. This is achieved by having one pin on the rear connector that mates after the other pins. This pin must be connected to negative bus volts and the rectifier will not start until this pin engages. If a rectifier will not start, ensure the rectifier is fully engaged in the connector in the rectifier shelf.

5.14 Interface - Rear Connector

The rear connector on the rectifiers is a TYCO Card Edge Connector. (The part number for the backplane side is 2085089- 1)

Figure 2: Rear Connector Pin Descriptions

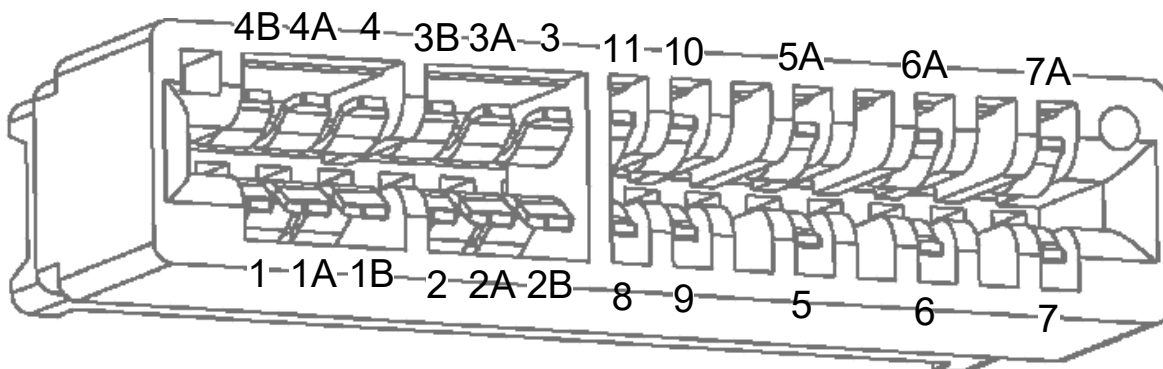

Table 3: Rear Connector Pin Configuration

Pin #	Description
Pin 1,4	Positive Output
Pin 2,3	Negative Output
Pin 5	AC protective Earth \oplus
Pin 6	AC neutral conductor N
Pin 7	AC live (phase) conductor P

Pin 8	Postmate
Pin 9	Rack Position
Pin 10	SBI Comms
Pin 11	Load share
Note: Unassigned pins should not be connected to anything and should be left isolated and voltage free.	

6 INSTALLATION

6.1 General Warnings

This rectifier contains no user serviceable components. Do not disassemble the rectifier.

To isolate the rectifier from the mains power, simply unplug from the rack or switch off at the distribution panel.



DANGER Do not operate the rectifier if the covers are damaged or removed in any way.



WARNING The rectifier contains voltages that may be lethal even after the input supply has been removed.



WARNING The rectifier contains components at high temperature that may burn if touched

6.2 Rectifier Shelf

The RM648HE rectifiers are designed to be used with the Newmar Sentinel DC Power Plant

6.3 AC Supply Surge Protection

The AC supply that feeds the rectifiers should have surge protection installed to meet levels defined for terminal equipment. Newmar recommend that IEC 62305-4(Protection against lightning - Part 4: Electrical and electronic systems within structures) be used to give guidance on the design of surge suppression systems.

6.4 Ventilation

The performance of the rectifier can be limited if the ventilation is restricted. The rectifier is cooled by drawing air into the front of the unit with a single fan. This air passes through the rectifier cooling the electronics and exiting the rectifier at the rear. To ensure this happens as efficiently as possible check the following:

- The air at the front of the rack is at ambient temperature and not being heated by other equipment.
- Ensure the rectifier shelf has at least 75mm clear horizontal space behind it. This space must be clear of cables and any other components that may restrict air movement.
NOTE: if multiple rectifier systems are installed then there should be at least 75mm clear horizontal space per shelf.
- The free space in the rack should continue vertically to the exhaust point at the top of the rack, without impediment.

- The hot exhaust air should not be allowed to re-circulate to the front of the rack as this will be drawn into the rectifiers again, in effect raising the apparent ambient temperature.

The rectifier must be operated in a low dust and fiber environment. If this cannot be guaranteed, then the rack should be fitted with air filters to prevent dust passing into the rectifier units. These filters need to be designed for adequate air volume and regularly maintained.

NOTE: Care must be taken to maximize the flow of cooling air. All cables and other obstructions must be kept clear of the rear of the rectifier as shown:

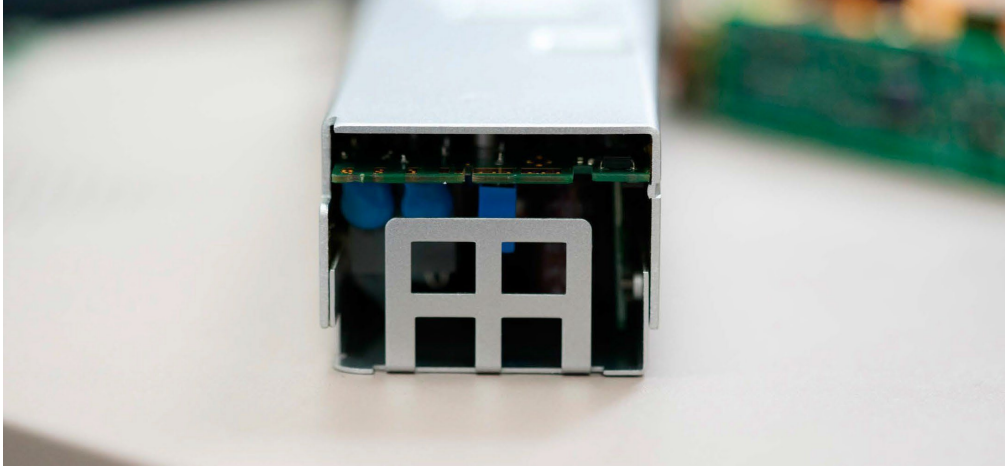

6.5 Rectifier Addressing

Each rectifier in the system has a unique address which identifies it to the monitor. This address is set by the position in the rectifier shelf. It is read by the rectifier from the backplane PCB and will change if the rectifier is moved to a new location. This address structure is set up when the system is built by the system manufacturer.

7 COMMISSIONING THE RECTIFIER

1. Check the polarity of the load and battery cables to the system are correct.
2. Plug the rectifier into the rectifier shelf using the following steps:
 - a. Locate the chosen slot in the system.
 - b. Push the rectifier into the system slot until the connector is fully engaged. (an audible click will be heard, the RM648HE uses an automatic locking catch)



c.

NOTE: Rectifier removal is achieved by lifting and holding the unlock button, then gently pulling on the front panel.



WARNING Hold the rectifier by the plastic cover. The rectifier metal case in extreme operating conditions becomes hot.



- Once the rectifier is installed into the rectifier shelf, the AC power can be turned on. After the initial startup period the rectifier will be set to the desired system parameters by the monitor module via the serial communications.

8 SPECIFICATIONS

8.1 AC Input

Operating Mode	110VAC Mode	230VAC Mode
Nominal Input Voltage	110VAC	230VAC
Input Voltage Range	85-175V AC (reduced power below 100V AC)	85-300VAC (reduced power below 175V AC)
Frequency Range	45-66Hz	
Power Factor	>0.99	
Peak Efficiency	>93.0%	>95.0%
Input Fuses	HRC Fuses in phase and neutral	
Maximum Input Current	5.2A	
Protection Input Voltage Input Inrush	Automatic shutdown, restarts when correct voltage is resorted <two times Maximum Input Current	

8.2 DC Output

Operating Mode	110VAC Mode	230VAC Mode
Nominal Output Voltage	48V Rated Voltage 54V Adjustable	
Voltage Range	43-60V Maximum	
Rated Current	12.5A	17.9A
Maximum Rated Power	600W	860W
Regulation Line Load Hold-up time Startup time	$\pm 0.1\%$ $\pm 0.5\%$ no load to full load >10ms for 20% output voltage drop Startup delay one (1) second (varies with AC supply voltage) Walk-in delay six (6) seconds at full output (varies with DC output voltage)	
Operating Mode		

Protection	
Power Limit	Adjustable to 50 – 100% of maximum rated current
Over Temperature	Automatic current turndown, backup shutdown protection
Polarity Reversal	Output Fuse with Crowbar diode in back plane
Over Voltage	Adjustable limit
Noise	
Ripple	Below 100Hz < 10mVRMS Unweighted Voice
Voice	100Hz to 5 kHz < 5mVRMS Psophometric
Band	Wide 5kHz to 1MHz <10mVRMS
Wide Band	0-20Mhz <100mV
Peak to peak	
Isolation	
Input to Output	4000V DC
Input to Chassis	3500V DC (VDR to chassis removed)
Output to Chassis	2100V DC

8.3 Environmental

Operating Ambient Temperature	Rated 25± 5°C [77± 9°F] Range -20°C to +75°C [-4°F to 167°F] (maximum output power is derated above 45°C [113°F])
Humidity	5 – 95% RH (non-condensing)
Altitude	<2500m above sea level De-rate maximum ambient temperature by 4°C per 1000m above sea level [7.2°F per 3,281 ft above sea level]

8.4 Mechanical

Dimensions (W, H, D)	55.0m [2.17 in], 44.45 [1.75 in] (1U), 260mm [10.24 in] overall (rack depth 245.0mm [9.65 in])
Weight	635g [1.4 lbs.]
Shipping Dimensions (W, H, D) in] Shipping Weight	60mm, 52mm, 325mm [2.36 in, 2.05 in, 12.80 in] 800g [1.8 lbs.]

8.5 Compliances

Safety	EN 62368-1
Electromagnetic Compatibility	CISPR 24, CISPR 32
AC Harmonics	EN 61000-3-2
AC Flicker and Fluctuation	EN 61000-3-3
Other	CE & RoHS compliant

8.6 Maximum Output Power

Figure 3: Maximum Output Power for 110VAC Mode

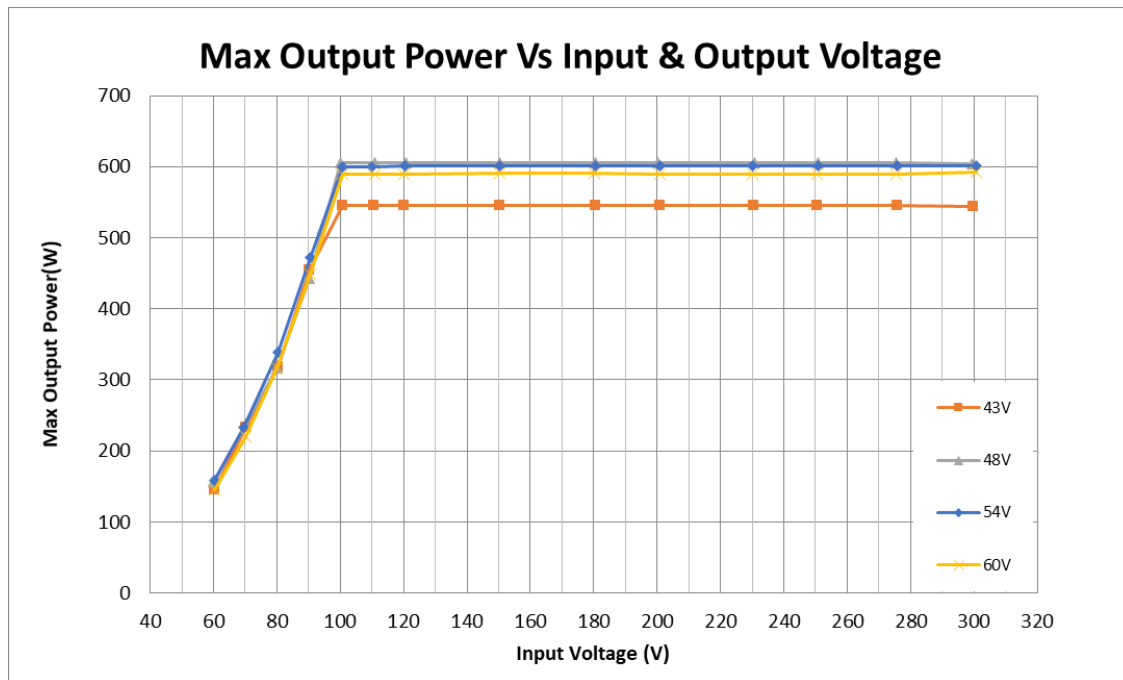
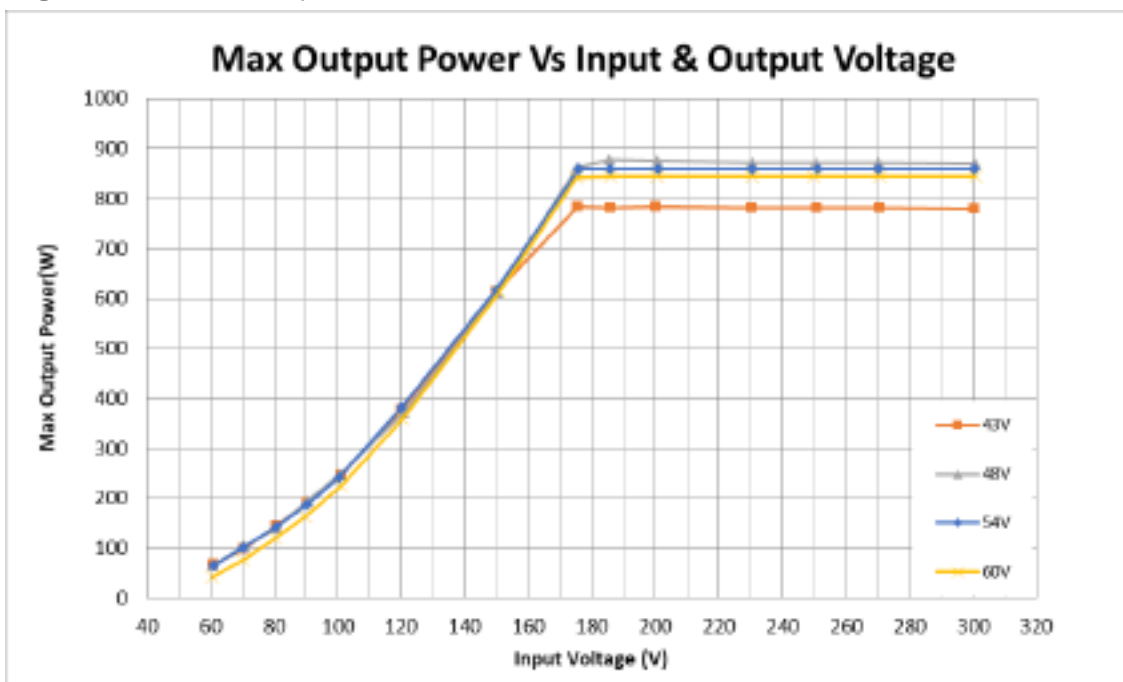

Figure 4: Maximum Output Power for 230VAC Mode



NOTE: Product specifications are subject to change without prior notice.

9 SERVICING

If the rectifier develops an operational fault, or is damaged in any way, contact Newmar Customer Service immediately.



DANGER Do not operate the rectifier if the covers are damaged or removed in any way.



WARNING The rectifier contains voltages that may be lethal even after the input supply has been removed.



WARNING The rectifier contains components at high temperature that may burn if touched

9.1 Troubleshooting

If the red  LED is alight:

- Unplug the rectifier and re-engage.
- Check AC power to the rectifier.
- Check for rectifier alarms in the monitor Urgent Alarm list. See [5.3 Indicators](#).
- If symptoms persist, contact a service agent.

If the yellow  LED is alight:

- Check the monitor Non-Urgent Alarm list. See [5.3 Indicators](#).

9.2 Fuses

Although there are fuses inside the rectifier, these are rated such that their failure indicates a fault requiring qualified service. **DO NOT ATTEMPT TO REPAIR THESE FUSES.**

NOTE: according to IEC 60950 the fuse ratings are required to be specified. The following fuses are soldered to the PCB: FH100 10A 250V ceramic slow blow wire end Fuse

9.2.1 Rectifier Input Fuse Curves

NOTE: The curves of Figure 5: Rectifier Input Fuse Curves are average value, for reference only

Figure 4: Rectifier Input Fuse Curves

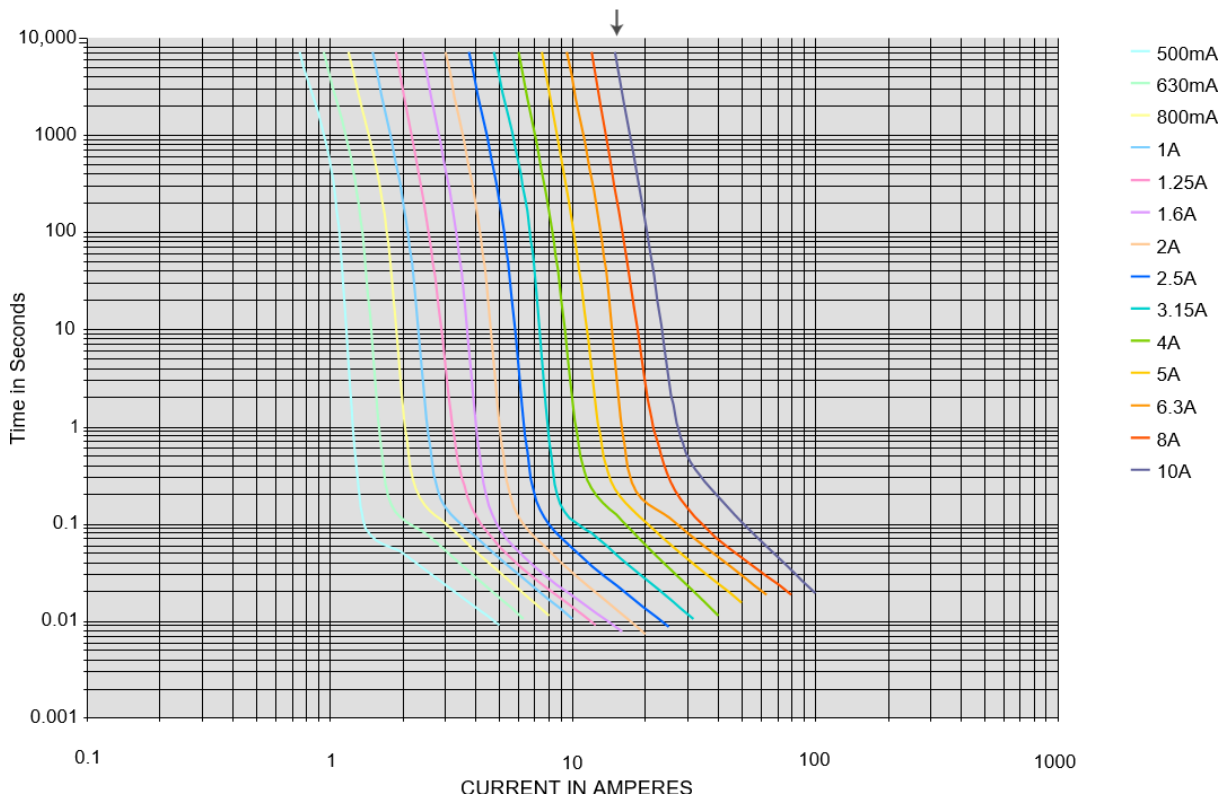

10 LEGACY SYSTEMS

If the RM648HE/RM848HE is being installed in an existing older Newmar DC power system, please note:

- It will always work with any Newmar system
- The Configuration Utility software used with the SM3x Supervisory Module if a release prior to Version 8.22 does not recognize the RM648HE/RM848HE in the system. It will report an “Unknown Device” in the rectifier module matrix of the Monitor page. However, the RM648HE/RM848HE will still be functioning correctly. The software version can be found on the top left of the Configuration Utility screen:

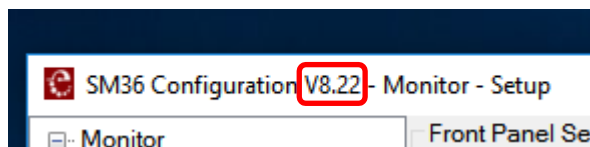

NOTE: you can update the configuration utility software by downloading the latest version from your Newmar Energy partner portal and installing it.

NOTE: key system parameters are stored in the monitor. Upgrading the Configuration Utility software will not cause you to lose custom settings.

Appendix I WARRANTY

Newmar warrants that this product is free from defects in material and workmanship and agrees to remedy any defect (or at its option replace the product) for a period of two years from the date of purchase. This warranty covers both parts and labor. Parts may be replaced under this warranty with new or remanufactured parts. This warranty will not apply to any product that has been improperly installed (as described in the installation manual), misused, abused, used in ways the product was not designed, altered, or repaired in any way which may affect the performance or reliability of operation, sustained damage by power surges or electrical storms, or sustained shipping damage, or repaired by any unauthorized repair center.

Please contact Newmar Customer Service to obtain a Returned Materials Authorization (RMA) prior to shipping any products for repair. All shipments must be shipped prepaid and include proof of the date of your original purchase. Please include your name, address, phone number, email address and a brief description of the problem.

Newmar makes no other warranties, express or implied, including any warranty of fitness for a particular purpose. In no event shall Newmar be responsible for indirect or consequential damages or lost profits even if Newmar has been advised of the possibility of such damages. Newmar sole obligation to you shall be the repair or replacement of a non-conforming product.