

TMR-30A Installation/Operation Manual

Install TMR-30A Power Timer in the vehicle and wire according to the drawing below. In the auto sense mode (ORANGE wire not connected) TMR-30A senses the charging system pick-up (engine running) to turn equipment on. TMR-30A starts timing when the engine stops. Low Voltage Disconnect is activated when the battery voltage falls below 10.5 volts for 25 seconds. High Voltage Disconnect occurs when the battery voltage exceeds 16.5 volts (3 second delay to prevent nuisance trip during load dumps, charging system start-up).

If the ORANGE wire is connected to a circuit that is hot when the ignition switch is on, your equipment will come on immediately with the ignition and timed disconnect will not occur. This configuration is recommended for emergency service vehicles to guarantee equipment operation during high electrical load conditions while idling.

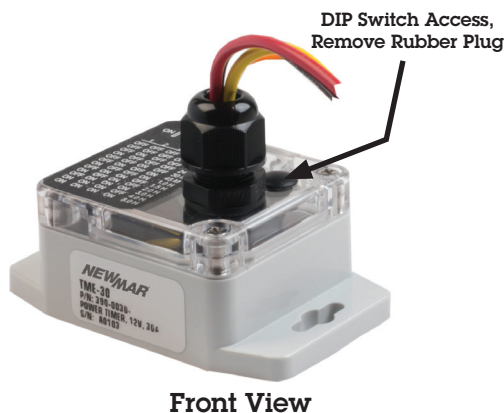

Model: 390-0030-1 (Rev. A)

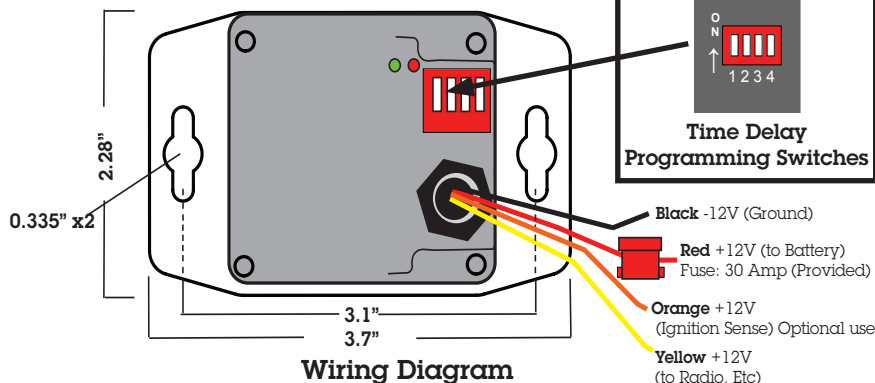

Setting Time Delay:

The time delay programming switches are on the top of the timer, see illustration. Remove the rubber plug to access the DIP Switches using a small slotted screwdriver or similar tool. See table below for switch positions/timer periods. Switches should not be changed while ignition is active. Ignition must be cycled before a new switch setting becomes active. Replace rubber plug when finished.

DIP Switch				Time Delay Setting
1	2	3	4	
OFF	OFF	OFF	OFF	6 Minutes*
OFF	OFF	OFF	ON	15 Minutes
OFF	ON	OFF	OFF	18 Minutes
ON	OFF	OFF	OFF	24 Minutes
OFF	OFF	ON	OFF	30 Minutes
OFF	ON	OFF	ON	45 Minutes
ON	OFF	OFF	ON	1 Hour
OFF	ON	ON	OFF	1-1/2 Hours
ON	OFF	ON	OFF	2 Hours
OFF	ON	ON	ON	3 Hours
ON	ON	ON	OFF	4 Hours
ON	ON	ON	ON	8 Hours

* Factory Default

There are **TWO LEDs** which function as follows:

Green LED: Output Power ON

Steady: Output power, no timing (>13.0V)
Flashing: Output power, timing (< 13.0V)

Red LED: Output Power OFF

Steady: No Output power, timed out
Flashing: No Output, low voltage (<10.5V)

Specifications:

Rating:

12V nominal, 30 amps,
13 mA standby current

Protection:

Low and high voltage disconnect
Low < 10.5V with 25 second delay
High > 16.5V with 3 second delay

Input Voltage Range: 10.5 to 16.5 VDC

Size: 3.7" H x 2.3" W x 1.4" D
(3" H with connectors and wires)

Temperature Range: -20 to 80° C

Warranty: 2 years



www.PoweringTheNetwork.com

M-TMR30A
As of 113016