

READ AND FOLLOW ALL SAFETY INSTRUCTIONS!

SAVE THESE INSTRUCTIONS!

IMPORTANT SAFEGUARDS READ AND FOLLOW ALL SAFETY INSTRUCTIONS.

- Do not use outdoors.
- Do not let power supply cords touch hot surfaces.
- Do not mount near gas or electric heaters.
- Use caution when servicing batteries. Battery acid can cause burns to skin and eyes. If acid is spilled on skin or in eyes, flush acid with fresh water and contact a physician immediately.
- Equipment should be mounted in locations and at heights where it will not readily be subjected to tampering by unauthorized personnel.
- The use of accessory equipment not recommended by the manufacturer may cause an unsafe condition.
- Do not use this equipment for other than intended use.

READ AND FOLLOW ALL SAFETY INSTRUCTIONS!

SAVE THESE INSTRUCTIONS!

M-PE12V100AH-UL
Issued: 082919

PE-12V-120-100AH-UL

Power Enclosure, 12 VDC, 120 Watts, 100 Amp-Hour Power System

Installation/Operation Manual

- Prepare To Install
- Installation
- Install Batteries
- BDS-DIN-UPS-12-10 Manual
- Cabinet Outline and Mounting
- Wiring Guide with Door LED Status Table

Specifications

Ratings

Input: 120V AC, single phase

Input Frequency: 60 Hz.

Maximum Input: 2.8 Amps *Use Copper Wire Only*

Output

Volts: 12.7V DC

Amps: 5

Rated Operating Time in Emergency Mode

Oper. Time: 5.0A @ 12 Hrs. Max. Load: 5 Amps

Battery

Install Only: GS Battery # PYL12V100FS Battery

Type: Sealed Valve Regulated Lead Acid

Voltage: +12 Volt

Quantity: 1



US ETL Certified to
UL Standard 924

Intertek
5010145

NEWMAR
PoweringTheNetwork.com

PE-12V-120-100AH-UL

Power Enclosure, 12 VDC, 120 Watts, 100 Amp-Hour Power System

Prepare to Install

- **System Contents:** Power Enclosure, Batteries (Packed Separately)
- **Details:** Installation Manual, Located Inside of Door
- **Door Key (x 2):** Attached to One of Enclosure's Bottom Mounting Holes
- **Wiring Accessories:** Polybag Inside Enclosure

CAUTION: Heavy Equipment

CAUTION: Contains Batteries

CAUTION:

- All wiring should comply with NFPA 1221 & National Electrical Code NFPA 70.
 - Input/Output wiring maximum length: 98.5 ft./30 meters.

Inspect Shipment Upon Receipt, Notify Carrier if Any Damage!

Material Provided:

- (1) NEMA 4 Power Enclosure
- (3) NPT-1/2" Liquid tight cord grips, clamping range: 6-11 mm
- (1) 12V DC, 100 AH sealed valve regulated lead acid AGM non-spillable battery w/terminal hardware

Overall Case Dimensions: 30" H x 23" W x 10.5" D

Door Hinge: Left Side



PE-12V-120-100AH-UL

Power Enclosure, 12 VDC, 120 Watts, 100 Amp-Hour Power System

Installation

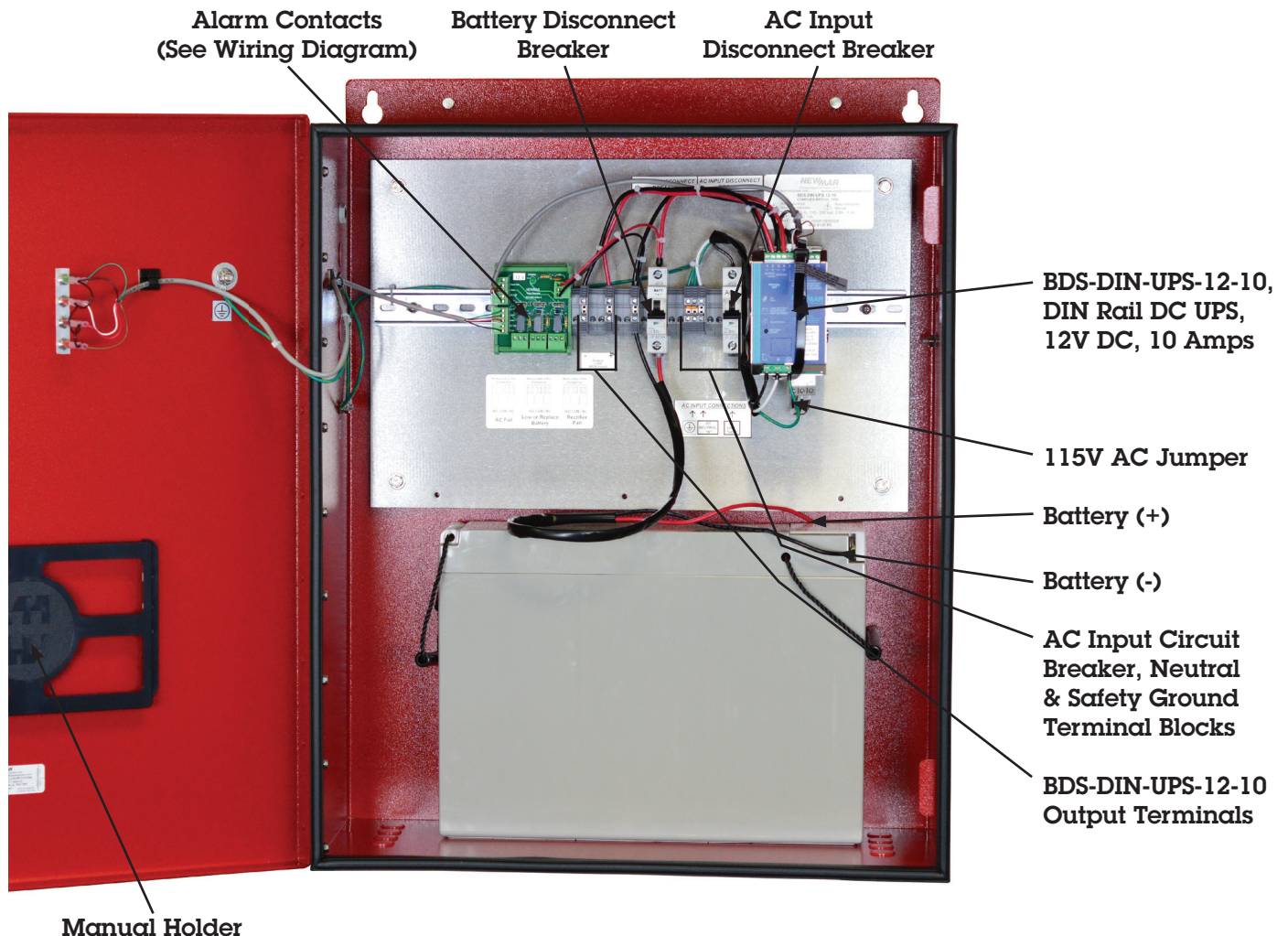

1. Mount enclosure on wall (customer supplied hardware) - see enclosure mounting drawings
2. Ensure both AC & battery disconnect circuit breakers are in OFF position
3. Qty. 3 liquid tight cord grips (NPT 1/2") are provided with the PE enclosure (clamping range: 6-11 mm). Two sets of four drill locators/dimples are provided on the upper left & right hand sides for drilling cable feed-thru holes. **NOTE:** Metal shavings can cause permanent damage to electronics. We recommend covering the electronics with a rag before drilling and remove shavings before energizing the PE System. Identify what drill size is required (7/8" drill for NPT-1/2") for your installation for the following cables and install cable fittings:
 - A. AC Input to BDA
 - B. DC Output to BDA, installer provided.
 - C. Alarm contacts (AC FAIL, BATT. LOW & RECTIFIER/CHARGER FAIL), installer provided.
4. Provide 120V AC (15A) circuit to PE system and connect to AC input circuit breaker (Hot) and terminal blocks (Neutral and Earth Ground)
5. Route BDA amplifier DC input cables thru cord grip, connect to "Output Load (BDA Input)" terminals
6. Route alarm cables through cord grip, connect to alarm terminal blocks on BDS-DIN-UPS 12-10 (see wiring diagram)

NEWBAP
PoweringTheNetwork.com

PE-12V-120-100AH-UL

Power Enclosure, 12 VDC, 120 Watts, 100 Amp-Hour Power System

Install Batteries

7. Install batteries in to enclosure per photograph
8. Connect battery cables from Battery disconnect circuit breaker and DC ground terminal block to 12 volt battery terminals per photograph/wiring diagram.
9. Energize 120V AC circuit
10. Turn on PE system AC disconnect circuit breaker and verify BDS-DIN-UPS 12-10 powers up. After one minute you should see the following:
 - A. AC FAIL LED: Off
 - B. BATTERY LOW/BATTERY REPLACEMENT LED: On (extinguishes when battery disconnect breaker is turned on, batteries connected)
 - C. DIAGNOSIS LED: 2 Blink/Pause
11. Confirm the BDA amplifier is receiving power
12. Confirm battery polarity is correct: RED wire to Battery Positive (+) & BLACK wire to Battery Negative (-). Turn on the battery disconnect circuit breaker, the diagnostic LED on the BDS unit should show one of the following:
 - A. 1 Blink/Second = Float Mode
 - B. 3 Blink/Second = Bulk charging mode (battery requires charge)
13. Verify battery voltage is approximately 13.8V DC (Float mode)

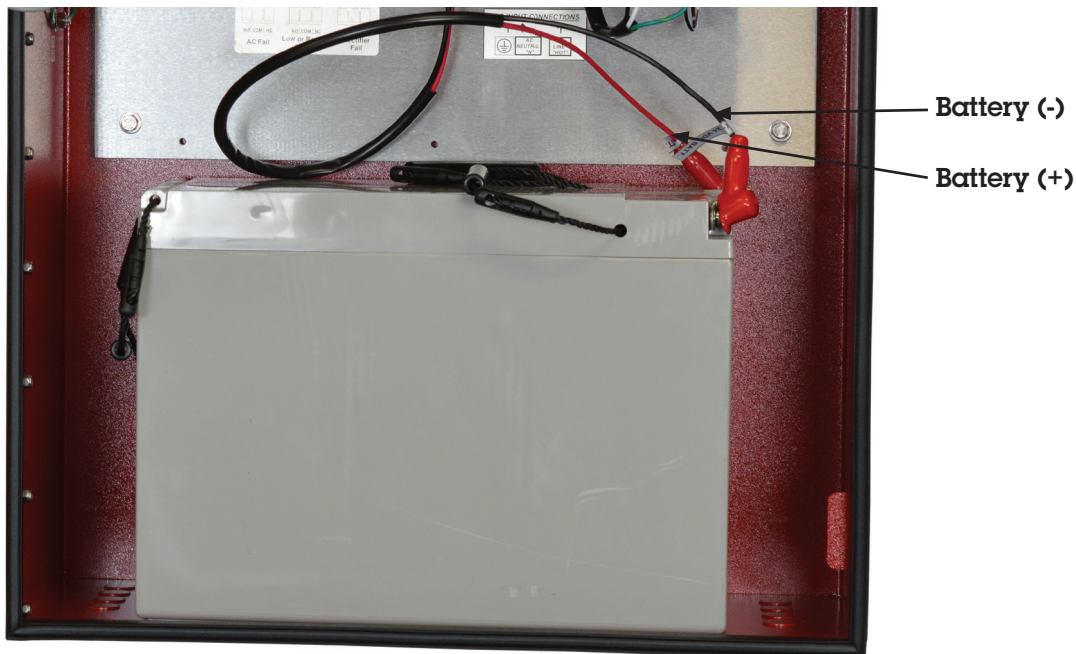



DIN Rail DC UPS

DC UPS / Battery Detection System

Model: BDS-DIN-UPS 12-10

Installation / Operation Manual



Table of Contents

| Section | Page | Section | Page |
|------------------------------------|------|---|------|
| 1) Overview / Quick Start | 2-3 | 5) Settings / Programming | 6 |
| 2) General Information | 3 | A) Battery Type / Charge Curve | 6 |
| Materials Provided | 4 | B) System Settings | 7 |
| Optional Equipment | 4 | 6) Operation | 8 |
| 3) Safety Information | 4 | A) Battery Start w/o AC Present | 8 |
| 4) Installation / Wiring | 4 | Push Button | |
| A) Mounting | 4 | B) Status Indicator LED's | 8 |
| B) Wiring | 5 | C) LVD | 8 |
| 1. Diagram | | 7) Protection | 8 |
| 2. AC Input | 5 | 8) Specifications / Dimensional Drawing | 9 |
| 3. Output | 5 | 9) Troubleshooting | 10 |
| C) Alarm Contacts, Form C | 5 | 10) Warranty | 10 |
| D) Temperature Compensation Sensor | 5 | | |



1

M-BDSDINUPS1210-ULPE
AS OF 010118

1) Overview/Quick Start

Figure 1: Function/Wiring Overview

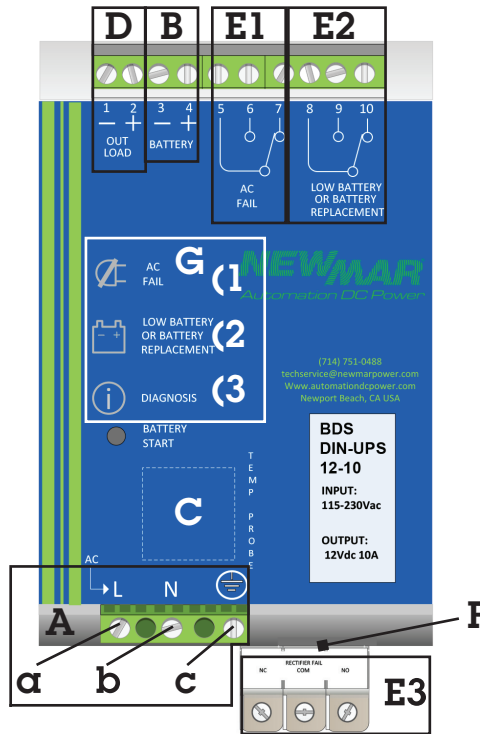

A) AC Input 90 - 305 VAC: Wire Input Block (lettered left to right)

- a) AC Hot
- b) Neutral
- c) Earth Ground

B) Battery Output: one terminal each for plus and minus. See page 5 for details.

C) Battery Temperature Sensor (optional): Plug in port (RJ-45). See page 6 for details.

D) Output to Load: The unit has a load priority circuit, all produced power is made available to the load, remaining power is available for battery charging. See page 5 for details.

E) Form C Contacts: Activate upon:

- E1.** AC Power Fail
 - E2.** Low Battery: (11.25V DC)
 - E3.** Charger Power Circuit Fail
- See page 5 for details.

F) System Settings: via plug-in jumper programming terminals located on bottom of the unit.

- a. Install jumper per illustration below (Table 1) to:
 - i. Select float voltage per Battery Type and enable Absorption Charge (see page 7 for details)
- See page 8 for details on functional settings.

G) Status Indicator LED's

1. AC Power Fail: Operating on battery back-up power (LED On). LED extinguishes when AC is present.
2. Low battery @ 70% discharge point, i.e. 30 capacity remains
3. Charger Output Status and Fault Mode Diagnosis: by blink code:

Charge Status Blink Code:

- Bulk: 5 blink/second - Recovery
- Absorption: 2 blink/second - Bulk
- Float: 1 blink/second

Fault Mode Diagnosis Blink Code:

- Reverse Polarity: 1 blink, pause
- Battery Not Connected: 2 blink, pause
- Overload or Short Circuit: 4 blink, pause
- Low battery alarm: steady on, 5 blink, pause
- Bad Thermal Sensor: 7 blink, pause and diagnostic

See page 9 for details.

H) Battery Start w/o AC Present Push Button: If system shuts down due to loss of AC and battery, pressing this push button will allow battery to reconnect and supply the load if sufficient battery voltage is present.

Mounting DIN DC UPS to DIN Rail

Removing DIN DC UPS from DIN Rail

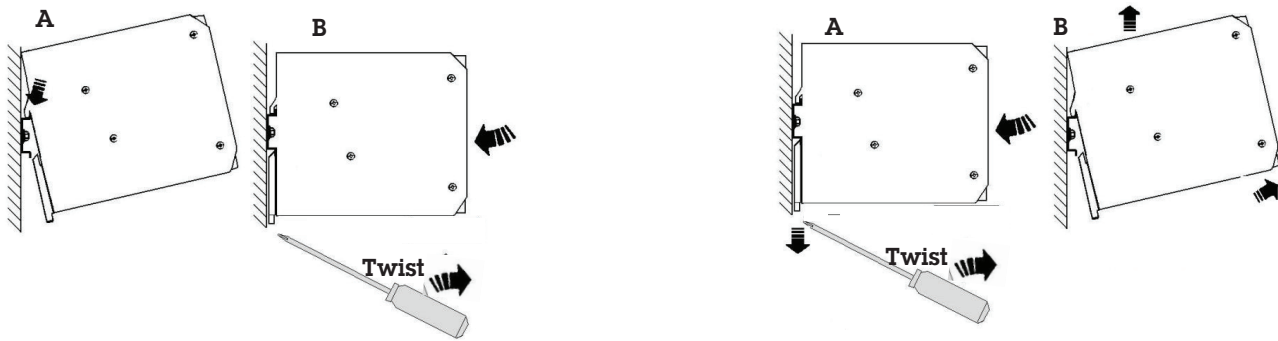

Insert flat head screwdriver in slot of bottom tab and twist to extend bracket

Table 1: System Settings: Battery Selection/Absorption Charge and Functional Settings

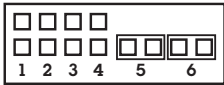
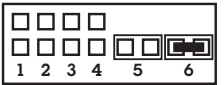
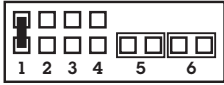
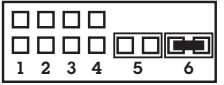
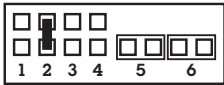
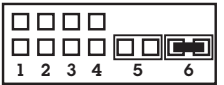
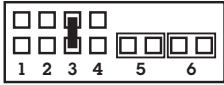
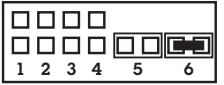
| Battery Type Selection | Float Charge/ Jumper Insert Position | Absorption Charge Enable/ Jumper Insert Position |
|---|---|---|
| Open Lead (Default) |  None 13.4 VDC |  Pos. 6 14.4 VDC |
| Sealed Lead Low Insert Jumper: Pos. 1 |  Pos. 1 13.5 VDC |  Pos. 6 14.4 VDC |
| Sealed Lead High Insert Jumper: Pos. 2 |  Pos. 2 13.6 VDC |  Pos. 6 14.4 VDC |
| Gel Battery Insert Jumper: Pos. 3 |  Pos. 3 13.8 VDC |  Pos. 6 14.4 VDC |

* Note, voltages above are at 20° C with no battery temperature sensor connected.

2) General Information

This DIN rail mount DC UPS Combines all system power functions: power supply, battery charger, UPS circuitry and status monitoring in one compact unit that produces 12 volt, 10 amps allocated via outputs for load and battery:

- Load output: "load priority" distribution ensures power is dedicated first to the load, with remainder then allocated to battery charging, thus preventing a discharged battery from impacting operation of critical loads.
- Battery output: 3 step charging for rapid battery recovery, programmable for battery type, with optional temperature compensation sensor
- Battery automatically on line to support load anytime AC fails
- Low voltage disconnect protects battery from total discharge
- High operating temperature range to 70° C

This DC UPS is fitted with special monitoring and alarm features designed to comply with the latest codes related to public safety in-building wireless communications back-up power requirements, as set forth by NFPA, section 1221,

In normal operation, the unit supplies power to the transmitter/antennas and maintains the back-up battery. Should an event occur that could cause interruption in power, self-diagnosis signals are sent via form C contacts notifying the network operators the system is running in a critical power condition and that potential communications failure is imminent.

- 1) AC Fail
- 2) Low battery voltage indicating battery discharged by 70% (i.e. 30% capacity remaining)
- 3) Internal charger/power circuit fail

Materials Provided:

- 1 ea. DIN-UPS unit with integral DIN rail mount clip
- 3 ea. Jumper tabs for programming

Tools Required

- Small 1/8" wide Flat Head screwdriver for terminal block connectors
- Large 1/4" wide Flat Head screwdriver for disengaging DIN Rail clip

Optional Equipment:

Temperature Compensation Sensor, P/N: 468-4510-0

3) Safety Information



WARNING – Explosion Hazard. Do not disconnect loads or battery unless AC input and battery have been switched off.

WARNING – Explosion Hazard. This product is not certified for Class 1, Div 2 applications.

WARNING – Switch off or remove AC input and battery power before wiring the DIN-UPS 12-10. Never work on the DIN UPS when it is connected to AC input and battery. The BDS-DIN-UPS must be installed in accordance with UL508 or local electrical codes depending upon the application. The BDS-DIN-UPS should have a suitability sized AC input circuit breaker feeding its AC input. See specification section for maximum AC input draw for your input voltage for circuit breaker sizing.

CAUTION: Hot surface. Avoid touching the DIN UPS case while operating at or near its full load capacity. Remove AC and battery power and allow BDS-DIN UPS at least 10 minutes to cool before removing from DIN Rail.

4) Installation/Wiring

A) Mounting:

The unit is designed for 35 mm DIN rail mounting in an enclosure or on a rackmounted DIN Rail bracket and relies on convection (free air) cooling, thus must have a minimum of 4" (10 cm) of open space above and below the BDS-DIN-UPS in order to assure sufficient air flow. We recommend approximately 1/2" (10mm) spacing between adjacent DIN Rail mounted devices. Note, that depending on the ambient temperature and load of the device, the temperature of the case can become hot to the touch.

The unit is designed for vertical mount (+/- 5°) and has an integral clip on the back to secure it to the rail. To mount, place the top tabs over the top of the DIN rail, and using a long slotted screw driver insert it in the groove at the bottom of the bracket and twist which will extend the spring loaded mounting bracket downward allowing the unit to be positioned against the DIN rail, release the bracket with BDS-DIN-UPS positioned vertically and the rail will be captured and the unit secured.

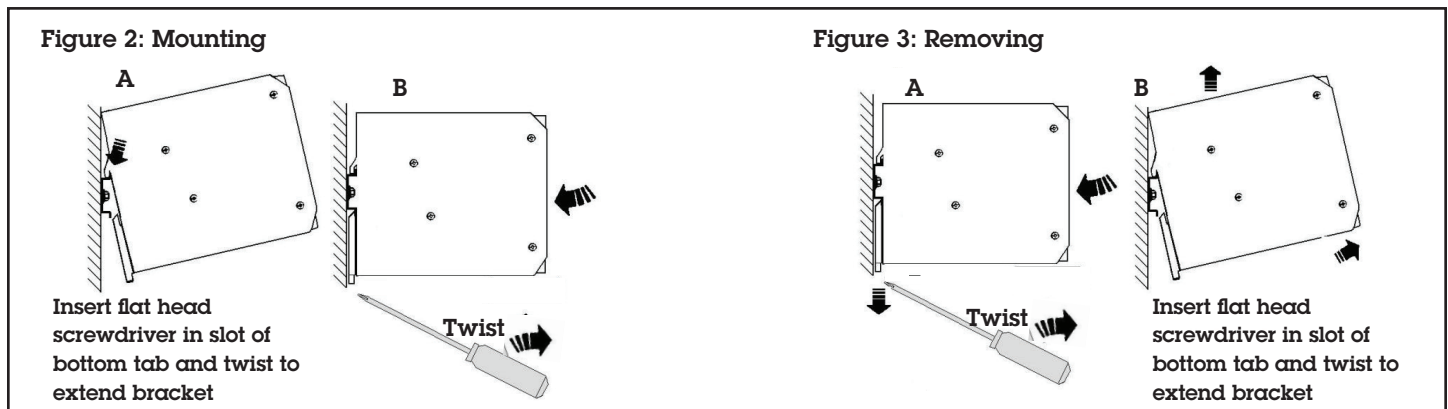

B) Wiring

1. AC Input: Terminal Block (lettered left to right) - Figure 4

- a) AC Hot/Line: 90 - 305 VAC
- b) Neutral
- c) Earth Ground

Recommended wire size: 16 AWG

2. Output

The unit has two outputs: one connects to the Load and the other to the back-up battery. Note: the unit has a load priority circuit, all produced power first is made available to the load with remaining power made available for battery charging. The DIN UPS is isolated from the case, thus you may apply to a positive or negative ground system.

Battery Output: See page 2, Section G for programming per battery type.

Output to Load: terminals for plus and minus.

Fuse note: We recommend a 15 amp fuse or circuit breaker be installed on the hot leg at battery.

Battery/Output wires size (recommended): 16 AWG

Terminal Block maximum wire size (recommended): 10 AWG

C) Alarm Contacts, Form C (Isolated):

Form C Contacts for remote monitor: Activate upon:

- a. AC Power Fail
- b. Low Battery, 11.25V DC - @ 70% Discharge Point*, i.e. 30% capacity remains
- c. Charger/Power Circuit Fail

* Applicable to battery systems with 2-5 amp continuous loads with 100 - 150 AH capacity

Table 2: Alarm Contacts

| Input | Contact | | | | 1 AC Fail LED | 2 Low Battery LED | 3 Diagnosis LED |
|-----------|---------|--------|--------|--------|---------------------|----------------------------|-----------------------|
| | 5-6 | 5-7 | 8-9 | 8-10 | | | |
| AC only | closed | open | open | closed | off | on | 2 Blink-Pause |
| AC + Batt | closed | open | closed | open | off | off | 1 Blink/sec |
| Batt only | open | closed | closed | open | on | off | off |
| Low Batt | open | closed | open | closed | on | on | off |

* Labeled Low Battery or Battery Replacement on Front Panel

Relay Contact Rating:

Max. DC: 30 VDC, 1 amp; AC: 60 VAC, 1 amp: Resistive load (EN 60947-4-1)

Min. 1mA at 5 VDC

D) Optional Battery Temperature Compensation Sensor P/N: 468-4510-0

To install, remove the access tab in the front panel decal labeled AUX Out, Figure 9, install the Temp. Sensor into the RJ-45 connector. Attach sensor to side of battery using RTV silicone.

The sensor will vary the battery charging voltage depending on the battery's temperature and charge program setting at a rate of 0.018 volts per degree °C.

Figure 4: AC Input Terminal Block

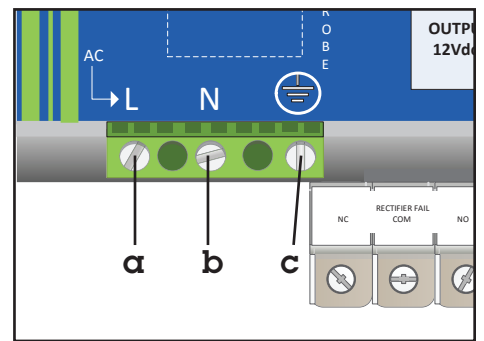

Figure 5: Output Terminals

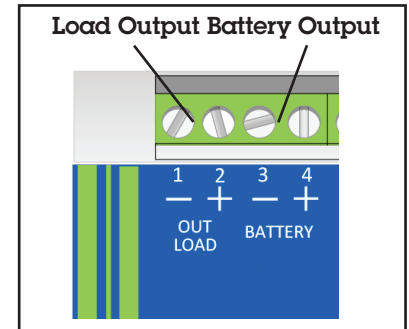

Figure 6: Alarm Contacts Terminals, Form C (Isolated)

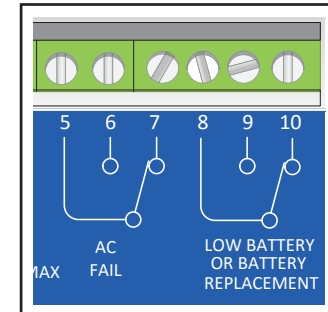

Figure 7: Charger/Power Circuit Fail Alarm Contacts

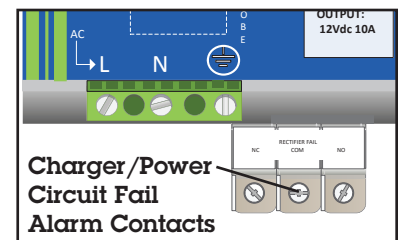

Table 3: Absorption Charge Voltage & Float Charge Voltage Settings with Temperature Sensor Installed

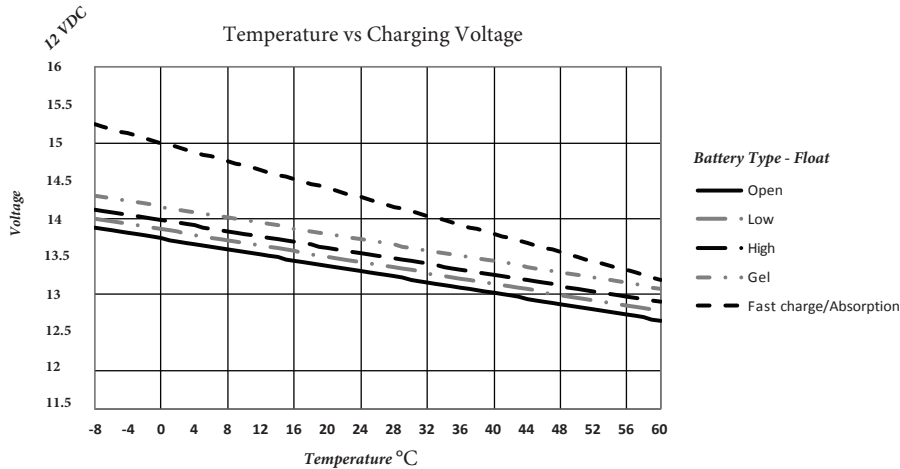
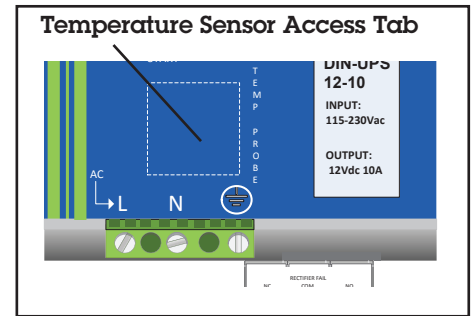

Figure 8: Battery Temperature Sensor Access Tab



Formula for determining temperature compensated Float or Absorption voltage based on battery temperature:

Float

Formula: Float Voltage = (13. * VDC) – (sensor temp. – 20° C) (.018 VDC)

* see Table 1 for Float voltage based on battery type selected

Example Conditions

- Battery selection jumper installed for 13.6 VDC Sealed Lead High Float voltage
- Battery temperature = 60° C

Float voltage =
 (13.6 VDC) – (60°C – 20° C) (.018 VDC) =
 (13.6 VDC) – (40° C x .018 VDC) =
 13.6 VDC – .72 VDC =

12.88 VDC Float @ 60° C

Fast Charge/Absorption

Formula: Fast Charge Voltage = (14.4 VDC) – (sensor temp. - 20° C) (.018 VDC)

Example Conditions:

- Fast charge/Absorption: 14. 4 VDC (same for all battery type selections)
- Battery temperature = 60° C

(14.4 VDC) – (60° C – 20° C) (.018VDC) =
 (14.4 VDC) – (40° C x .018 VDC) =
 14.4 VDC – .72 VDC =

13.68 VDC Absorption @ 60° C

If the battery temperature is less than -20° C or greater than +60° C, an 'outside its range (temp. sensor)' alarm is signalled with 7 blink code.

5) Settings/Programming

A) Battery Type/Charge Curve

Charge curve per battery type: via programing jumpers insterted on bottom panel of unit right side

Using programming jumper tabs provided and a small needle nose pliers, insert programming jumpers to select float voltage and enable absorption voltage per per battery type. Caution do not program unit while connected to power.

Figure 9: Battery Type Program Selection

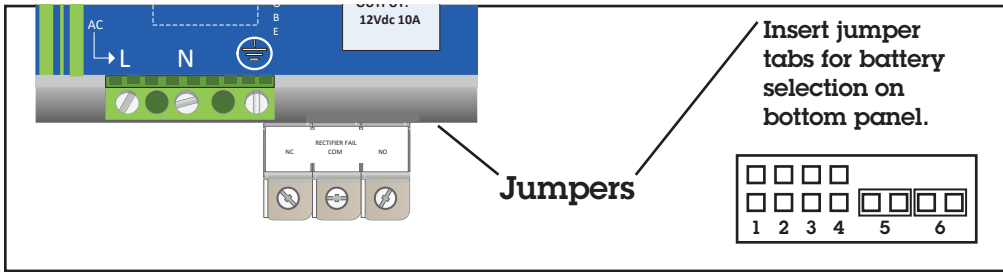

Table 4: Battery Selection/Absorption Charge

| Battery Type Selection | Float Charge/ Jumper Insert Position | Absorption Charge Enable/ Jumper Insert Position |
|---|---|---|
| Open Lead (Default) | <p>None</p> <p>13.4 VDC</p> | <p>Pos. 6</p> <p>14.4 VDC</p> |
| Sealed Lead Low Insert Jumper: Pos. 1 | <p>Pos. 1</p> <p>13.5 VDC</p> | <p>Pos. 6</p> <p>14.4 VDC</p> |
| Sealed Lead High Insert Jumper: Pos. 2 | <p>Pos. 2</p> <p>13.6 VDC</p> | <p>Pos. 6</p> <p>14.4 VDC</p> |
| Gel Battery Insert Jumper: Pos. 3 | <p>Pos. 3</p> <p>13.8 VDC</p> | <p>Pos. 6</p> <p>14.4 VDC</p> |

* Note: voltages above are at 20° C with no battery temp. sensor connected.

B) System Settings

Via plug-in jumper, programming terminals located on bottom right of the unit. Install jumper per illustration below to Enable Battery Test.

Table 5: Functional Settings

| Function Setting | | |
|--|---------------|---|
| Battery Test ON Insert Jumper: Pos. 4 | <p>Pos. 4</p> | <p>Insert jumper at position 4 to enable Periodic Battery condition test process. (Fault reported by LED diagnosis blink code, see Table 6):</p> <ul style="list-style-type: none"> ▪ Battery wiring connection ▪ Battery efficiency/sulfation (impedance test) ▪ Shorted Cell |

6) Operation

A) Battery Start without AC Present Push Button:

If the system shuts down due to loss of AC and battery power, pushing button will allow battery to come on line to supply the load. Press and hold for 3 seconds to re-connect battery to output. Note, if LVD has activated and battery voltage has not recovered above disconnect point, the unit will not cycle on.

B) Status Indicator LED's

1. Power source: Mains or back up
 - i. AC OK (AC Fail LED Off)
or
AC Fail
 - ii. Operating on battery backup power
(AC Fail LED On) red
2. Low battery, or battery replacement

LED illuminates when:

- Low Battery @ 70% depleted (11.25V DC), i.e. 30 capacity remains 3 diagnosis LED.

3. Charger output status system diagnosis and Fault mode diagnosis: by blink code (Table 6 below).

Figure 10: Status Indicator LEDs

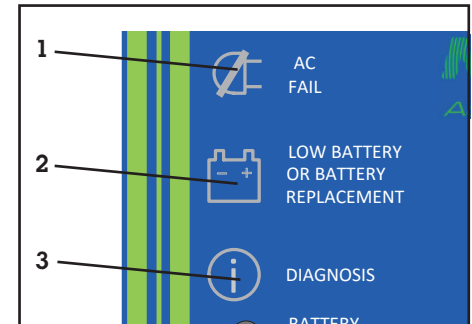

Table 6: Status Indicator LEDs

| Monitoring Control | State | LED Diagnosis (No.8) | LED Battery Fault No.7) |
|-----------------------|---|----------------------|-------------------------|
| Charging Type | Float | 1 Blink/sec | OFF |
| | Absorption | 2 Blink/sec | OFF |
| | Bulk | 5 Blink/sec | OFF |
| System Auto Diagnosis | Reverse polarity or high battery Voltage | 1 Blink/pause* | ON |
| | Battery Not connected, no output power | 2 Blink/pause | ON |
| | Over Load or short circuit on the load | 4 Blink/pause | ON |
| | Low battery; 45.6 volts | 5 Blink/pause | ON |
| | Battery Life test not possible | 6 Blink/pause | ON |
| | Temp. Sensor outside its range | 7 Blink/pause | ON |
| | Boost condition; battery discharge after 4 min. of overload. | 8 Blink/pause | ON |
| | Internal fault | 9 Blink/pause | ON |
| | Low battery detected when system activated by battery start button with no AC input | 10 Blink/pause | ON |

* Pause: 1 Second

C) LVD

The unit contains a low voltage load disconnect that activates at 9 volts (1.5 vpc) which is factory set and cannot be user modified.

7) Protection

On the AC Input: the device is equipped with an internal fuse. If the internal fuse is blown, it is most probable that there is a fault in the unit. If this occurs, the unit must be returned to the factory.

On the DC Output Battery and Load: The device is electrically protected.

Reverse polarity: the module is automatically protected against reverse of battery polarity and connection of reverse polarity.

Over current and output short circuit: the unit limits the output current. Low voltage disconnect protects battery from deep discharge.

Thermal Protection

Operating temperature range -12 to 70° C. Unit will produce full rated power on continuous basis to 50° C, however; system load must be reduced by 2.5% per 1° for continuous operation above 50° C. If the temperature reaches 70° C, the unit will reduce its maximum output to approximately 50% of its rating. If the temperature exceeds 70° C, the unit will shut off and restart once temperature drops.

8) Specifications

Input:

Voltage: 90 - 305, 47-63 hz

Amperage: 2.8 @ 120 VAC / 1.3 @ 230 VAC

Output: 12 volts, 10 amps total available to power loads and charge battery, with load priority distribution.

Peak: 30 amps 4 seconds (with battery power boost)

Low Voltage Disconnect Point: 9 VDC

Output ground isolated from case, may be used in positive ground applications. LVD function is lost

Front Panel LED Indicators:

- Power Source: operating on back up – red AC Fail LED
- Battery and System Diagnostics (via blink code)

Settings/Selectors:

- Battery Type: AGM, Sealed Lead Acid, Gel-Cell

Alarm Contacts (form C): Active:

- AC Fail (on battery back-up)
- Low Battery 11.25V DC: indicating 70% battery discharge point (i.e. 30 capacity remains based on 2 - 5 amp continuous load on 100 - 150 AH battery)
- Charge Fail contacts

Operating Temperature: -12 to 70° C. Continuous to 50°, de-rate 2.5% per° C >50° C

Cooling: Free air convection

Efficiency: 90 @ 50% load

Humidity: to 95%, to 25° C

Power Dissipation: 17 Watts

BTU's: 58

Protection:

- Low Voltage disconnect at 1.5 volts per cell (9 VDC)
- Internal fuse
- Current limiting
- Short circuit
- Reverse polarity
- Thermal overload shut down and recovery
- IP 20

Case Size: 4.5" H x 2.6" W x 5.3" D

Design Standards:

- CE Mark
- Designed to UL 1950

Terminal Blocks: Screw type

Mounting: DIN Rail Bracket 35 mm

9) Troubleshooting

| Symptom | Possible Cause | Corrective Action |
|---|---|--|
| A. Battery requires excessive re-charge time | <ol style="list-style-type: none"> 1. Load at or near max. recommended load providing minimal current available for charging 2. Charging level current set to low | <ol style="list-style-type: none"> 1. Reduce load or split load between two separate DIN UPS units 2. Adjust "Battery Charging Level" control knob to higher level |
| B. Load turns off after a couple of seconds when running on battery | <ol style="list-style-type: none"> 1. Batteries not charged, due to high load demand | <ol style="list-style-type: none"> 1. Reduce load or split load between two separate DIN UPS units |
| C. No absorption voltage | <ol style="list-style-type: none"> 1. Absorption jumper not installed | <ol style="list-style-type: none"> 1. Install provided jumper in position 5 |
| D. Trips AC input breaker | <ol style="list-style-type: none"> 1. AC shorted to case 2. Defective unit | <ol style="list-style-type: none"> 1. Verify correct AC input wiring 2. Contact technical service |
| E. No output | <ol style="list-style-type: none"> 1. DC output wired backwards or shorted 2. No AC input 3. Excessive temperature or blocked ventilation 4. Defective unit | <ol style="list-style-type: none"> 1. Remove AC input and check DC wiring 2. Verify correct AC input 3. Improve ventilation, unblock vent holes 4. Contact technical service |
| F. No voltage on battery output terminals | <ol style="list-style-type: none"> 1. No battery installed (voltage required for battery output to turn on) 2. Missing or blown battery wiring fuse | <ol style="list-style-type: none"> 1. Install batteries 2. Replace missing or blown battery wiring fuse |
| G. Diagnosis LEDs always blinking | <ol style="list-style-type: none"> 1. Normal operation | <ol style="list-style-type: none"> 1. Refer to Chart 2: Diagnosis Table |

10) Warranty

Newmar warrants that the BDS-DIN-UPS 12-10 DIN Rail DC UPS/Battery Detection System to be free from defects in material and workmanship for two years from date of purchase. If a problem with your BDS-DIN-UPS 12-10, or if you have any questions about the installation and proper operation of the unit, please contact NEWMAR's Technical Services Department:

Phone: 714-751-0488 - From the hours of 7:30 a.m. to 5:00 p.m. weekdays, P.S.T.;

Fax: 714-957-1621

E-mail: techservice@newmarpower.com

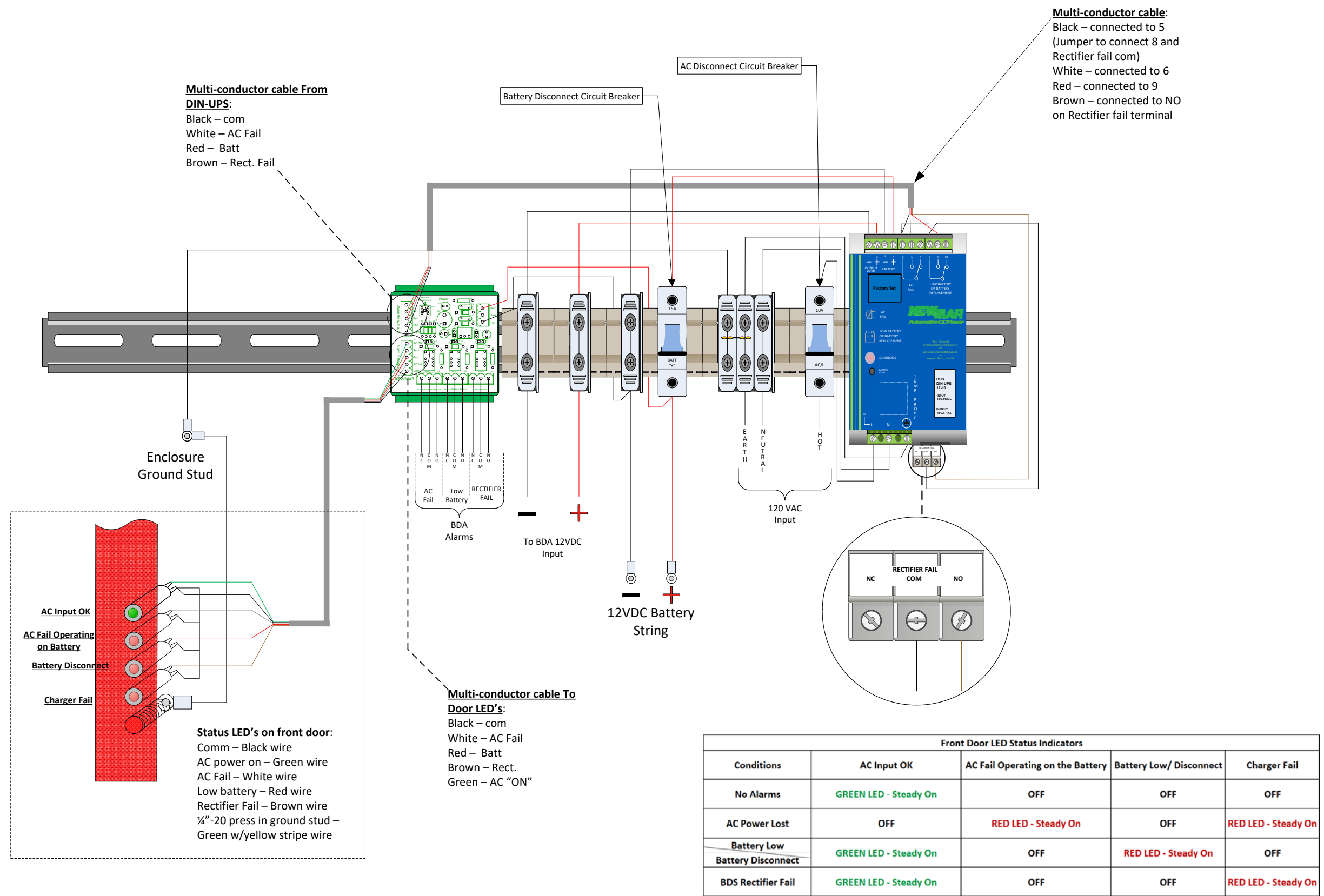

***Notes:**

1) BDS unit factory wired for **120** VAC Input

Wiring Diagram: PE-12V-120W-18AH/55AH/100AH-UL
Revision: A
Drawn By: R. Wirtz

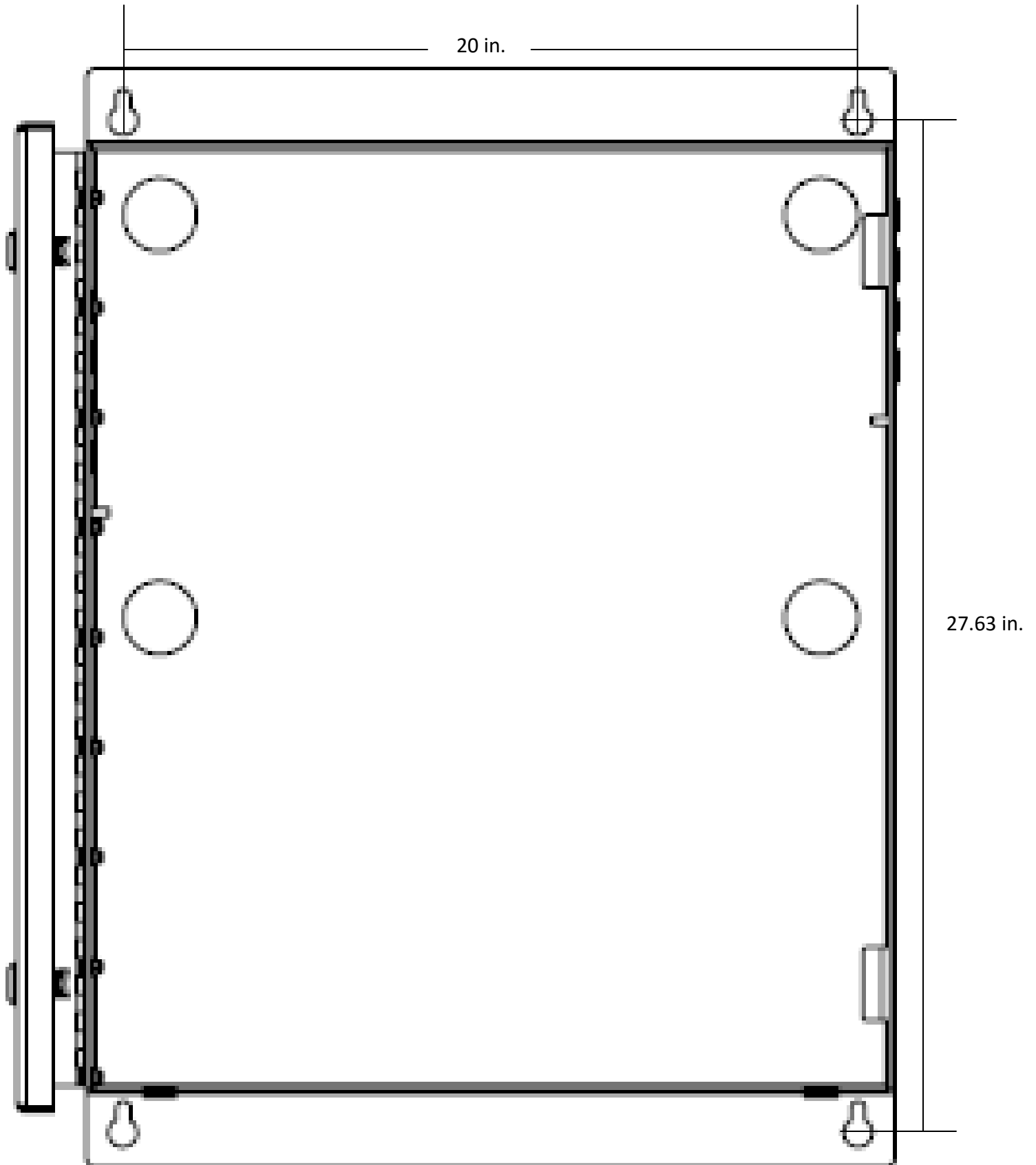

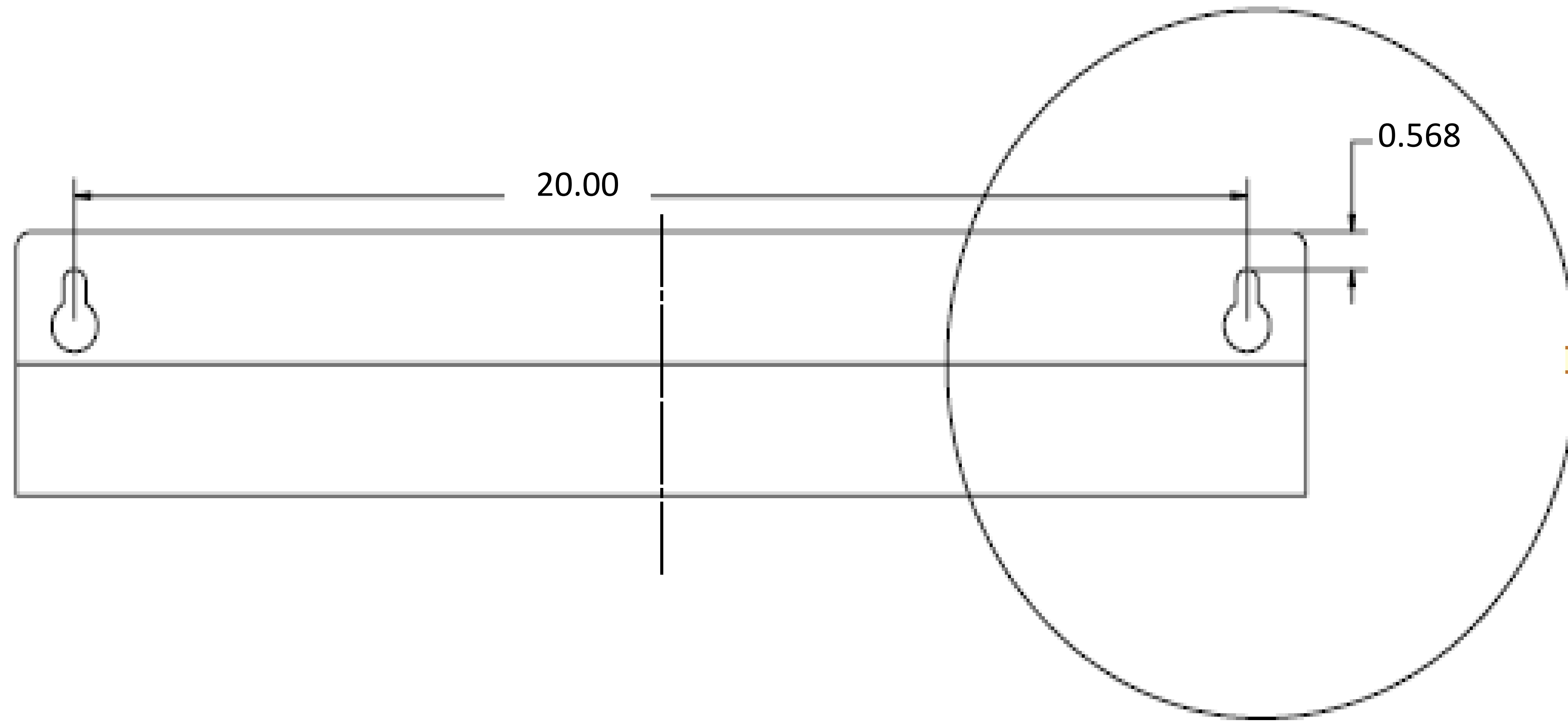
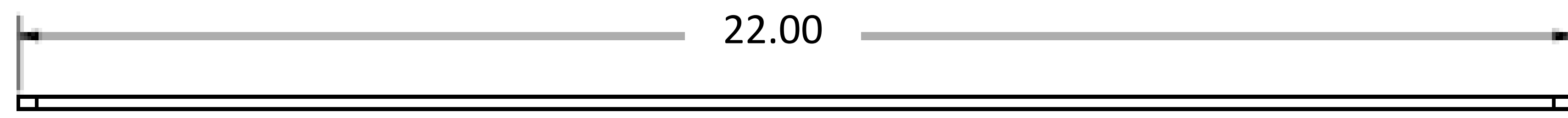

TOP MOUNTING LIP

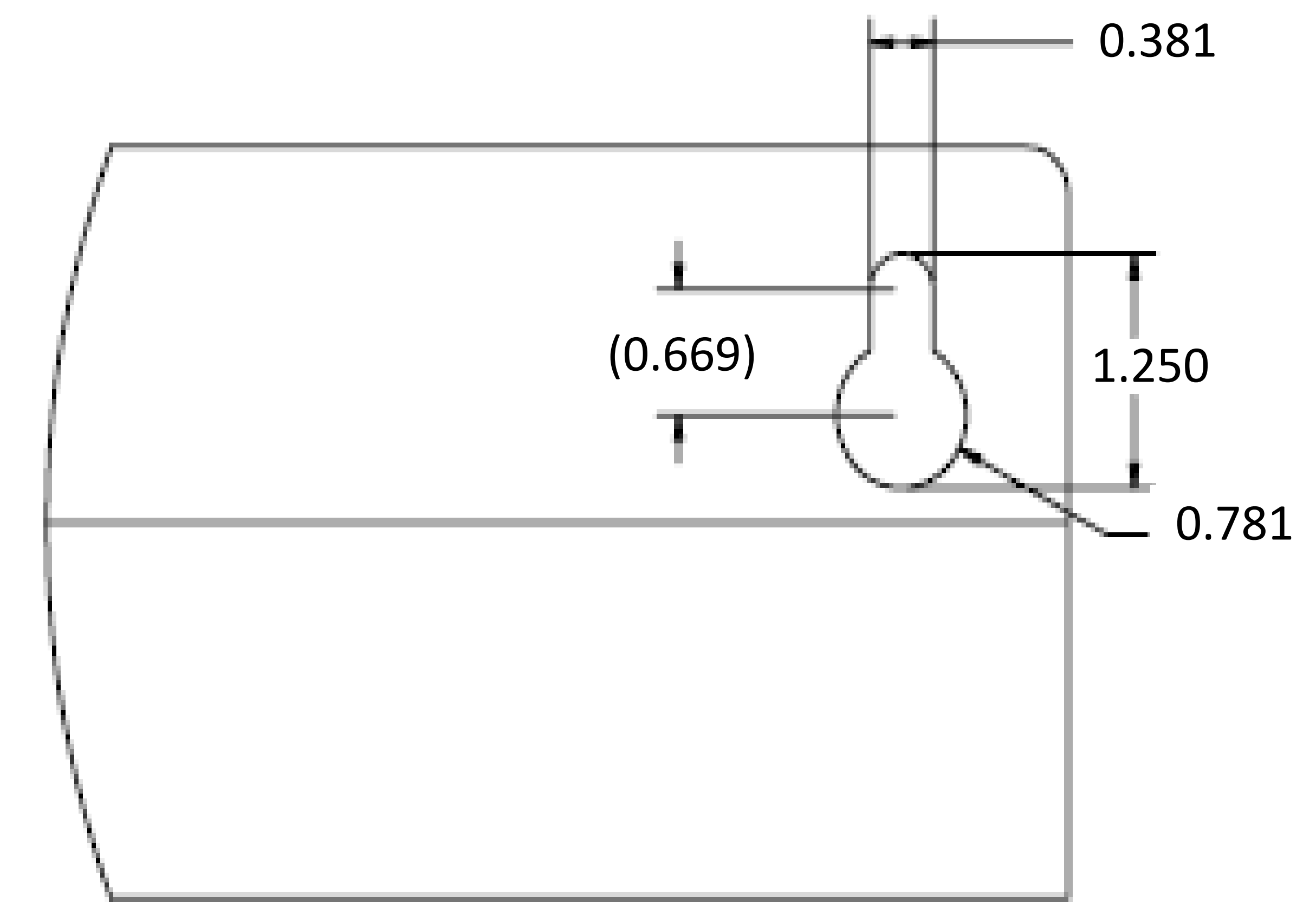

**DETAIL B
SCALE 1:1**

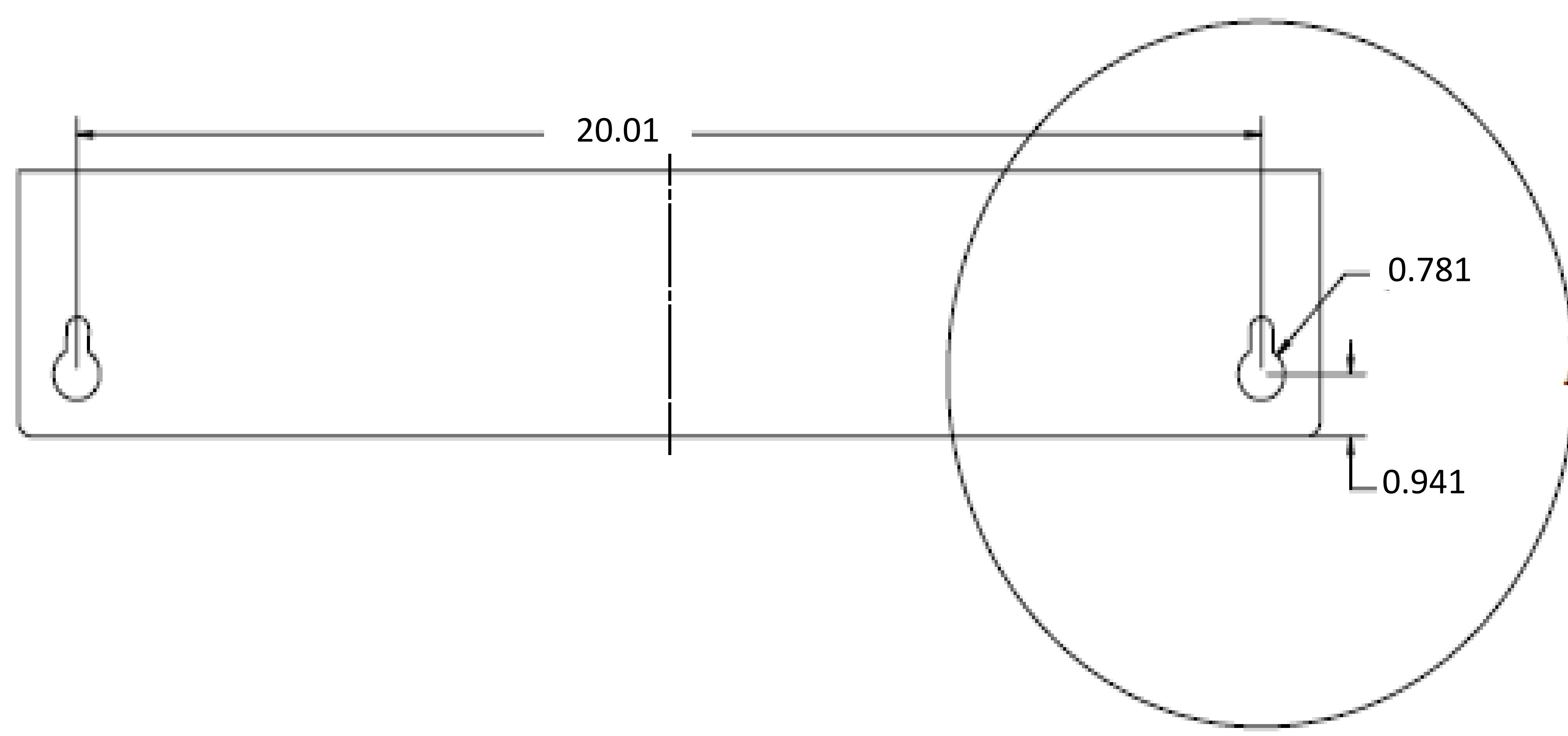
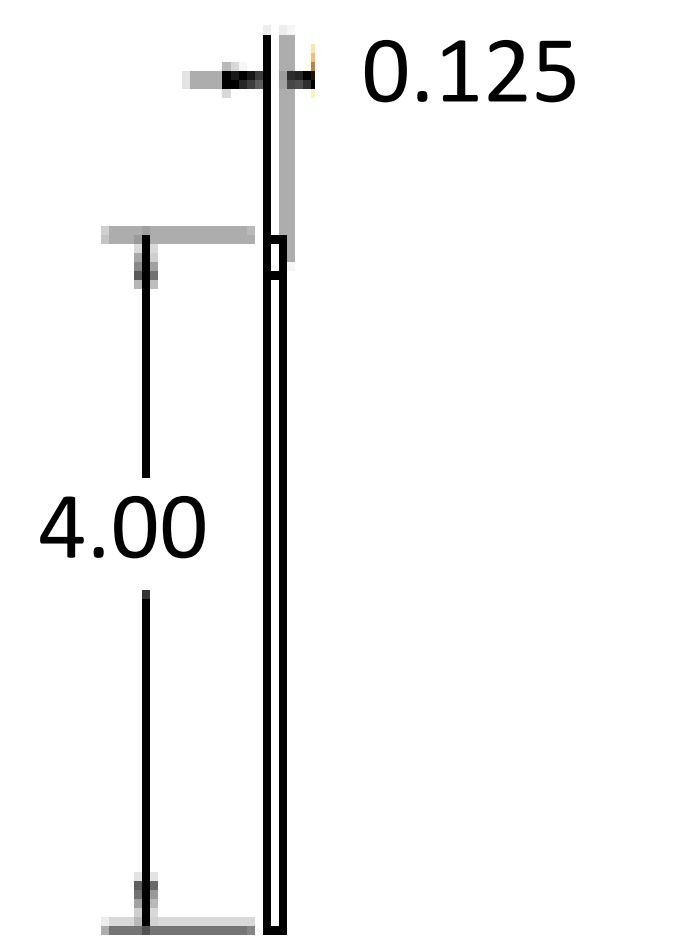

BOTTOM MOUNTING LIP

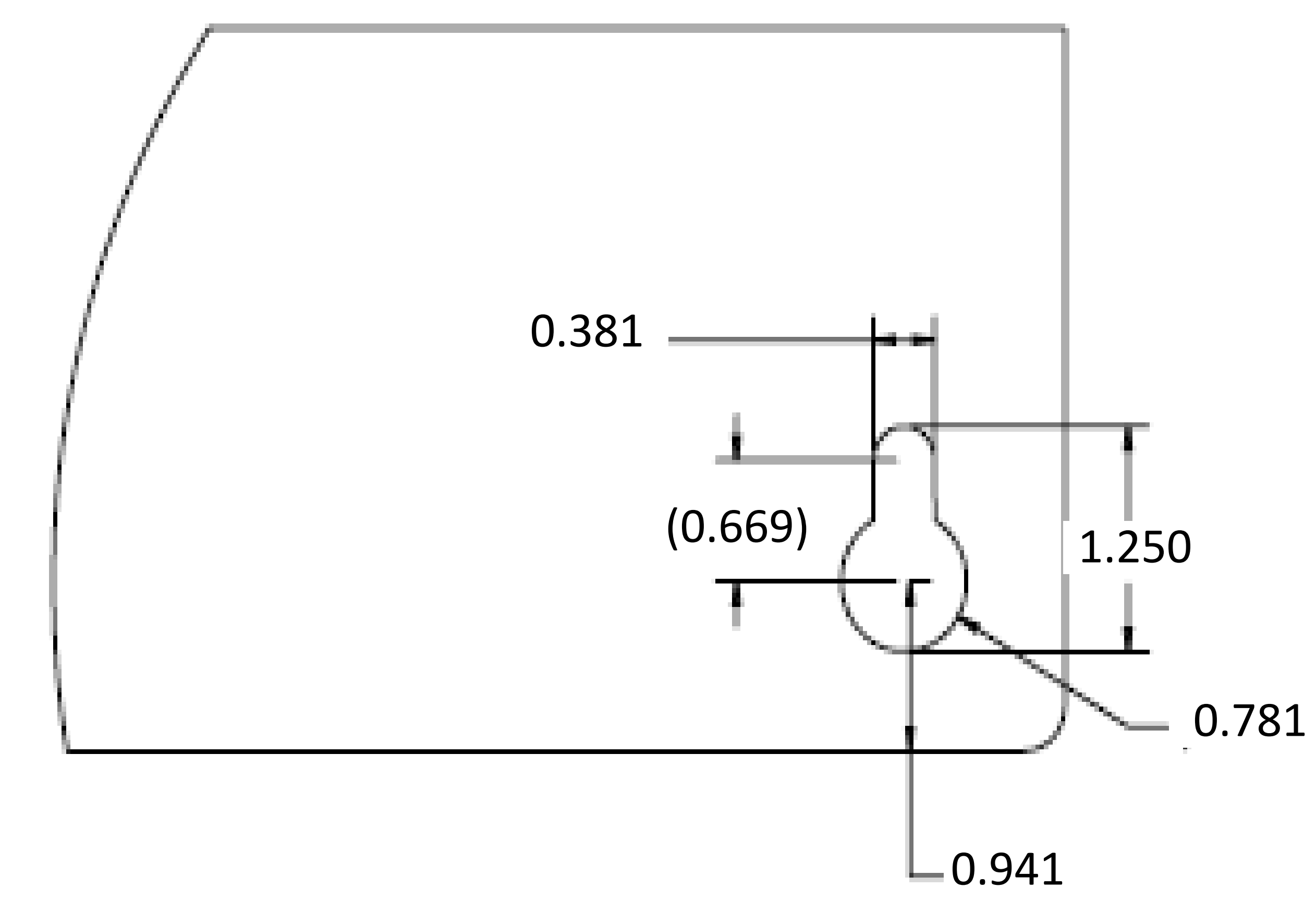

**DETAIL A
SCALE 1:1**

