

Power Function Manager

MODEL: PFM-500

INSTALLATION / OPERATION MANUAL

<u>SECTION</u>	<u>TOPIC</u>	<u>PAGE</u>
I)	OVERVIEW.....	3
II)	INSTALLATION.....	3
	A) Materials Provided.....	3
	B) PFM Mounting.....	3
	C) Bus Bar Mounting.....	3
	D) Input Voltage Selection (Universal) and Wiring..	3
	1) Simplified Wiring Option	
	DC Quick Connect Wiring Kit	
	2) Standard Wiring	
	E) Output Wiring.....	5
	1) Unswitched Output	
	2) Switched Output	
	F) Battery Wiring.....	6
	G) Status and Alarm Contact Wiring.....	7
	H) Chassis Grounding.....	8
	I) Circuit Breakers.....	8
	1) Breaker Installation	
	2) Breaker Functions	
III)	FRONT PANEL INDICATORS, DISPLAY AND SETTINGS.....	10
	A) Settings.....	10
	1) Meter Power Source Selector Switch	
	2) LVD Switch	
	B) INDICATORS.....	11
	1) Alarm LVD	
	C) LCD DISPLAY.....	11
	1) Screen Selection Flow Chart	
	2) Programming Sequence	
	D) LVD Operation and Programming.....	13
	1) Manual/Auto Selector Switch	
	2) LVD Adjustment	
	3) LVD Alarms	
	4) LVD Voltage Sequencing Example	
IV)	TROUBLESHOOTING.....	14
V)	SPECIFICATIONS.....	16
VI)	BREAKER SPECIFICATIONS/ORDERING GUIDE.....	16

M-PFM500
As of 112818

QUICK REFERENCE CONTENTS

Each of the main front or rear panel accessible features of the PFM-500 is illustrated below, along with the page number where information on that particular feature is located.

FIGURE 1: PFM FRONT PANEL

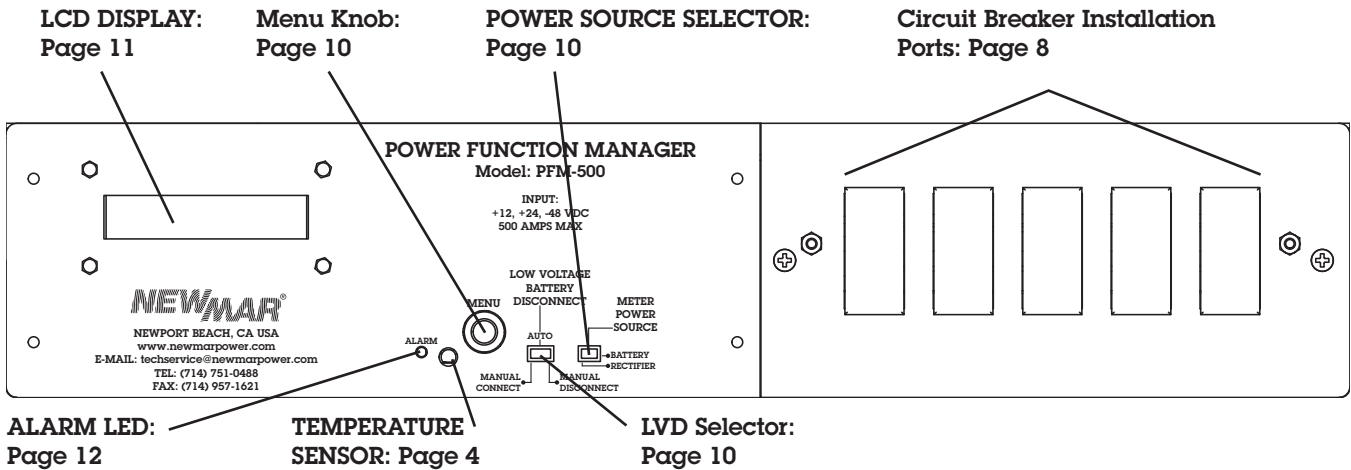
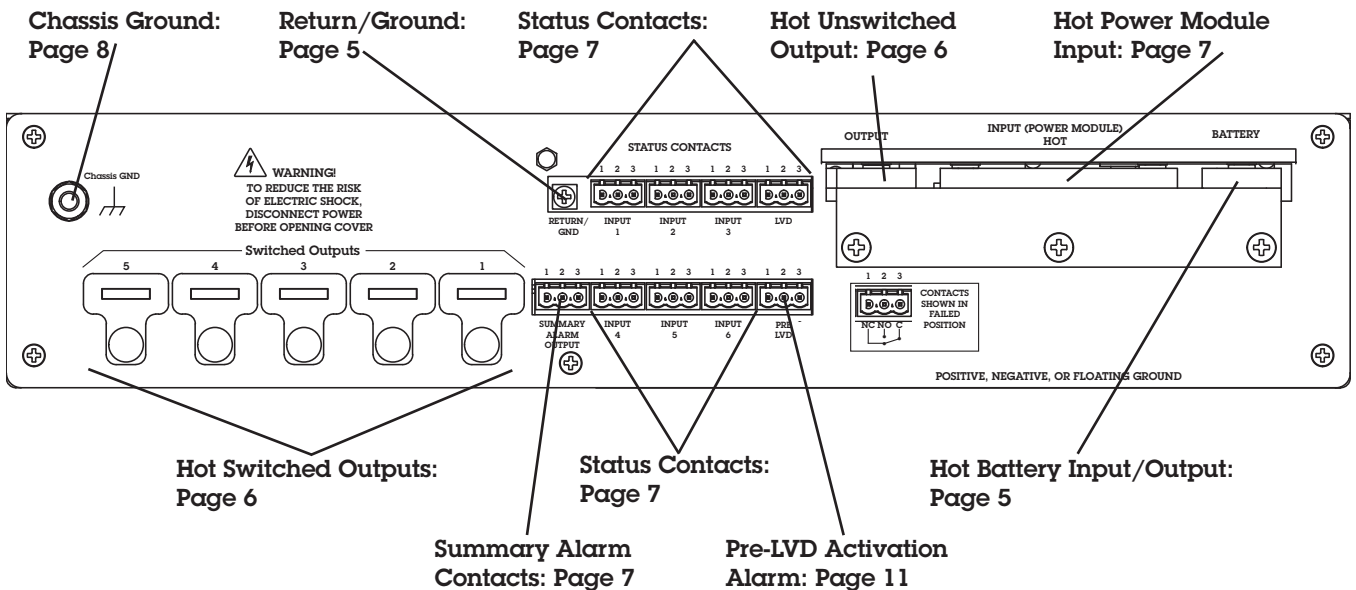

FIGURE 2: PFM REAR PANEL



I) OVERVIEW

The Power Function Manager (model PFM-500) converts multiple DC power sources (or NEWMAR Power Modules) into a fully integrated and multi-functional power system. The unit provides control, monitoring, paralleling and protection of 12V, 24V or 48V DC, positive, negative or floating ground power sources.

A heavy duty (**500 amp**) parallel bus bar, digital metering, individual power source and total system status lights, five load distribution breaker capacity, low voltage battery disconnect and summary alarm contacts are all combined into the compact, rackmount housing of the PFM, which serves as a master DC power management and distribution center.

The PFM may be used for integration, control, monitoring and protection of numerous different types of power sources, such as AC-DC rectifiers, regulated power supplies or DC-DC converters. In addition, any rack power product, including distribution panels, can be connected to the PFM's alarm system, provided they employ form C or Normally Open (NO) alarm contacts. For simplicity of explanation in this manual, reference is made to the NEWMAR Power Module as the power source(s).

Note: Installation of Oring diodes is required for paralleling of DC power sources. Oring diode output is standard on NEWMAR PM Series Power Modules.

II) INSTALLATION

A) Materials Provided

Prior to installation, please check to see that each of the following items have been included with the PFM. Check both the information packet and the cardboard insert which is labeled "ACCESSORIES INSIDE". For any missing items please contact the factory or warehouse.

- | | |
|---|---|
| (2) ea. Mounting Ears for 19" rack mounting | (6) ea. 1/4"-20 x 1" Hex Head Screws S.S. (Input/Output Busbar Wiring) |
| (6) ea. 6-32 X 3/8" Phillips Screws (for mounting ear) | (11) ea. 1/4"-20 Hex Nut S.S. (Input/Output Busbar Wiring) |
| (1) ea. Circuit Breaker Finger Guard Cover | (11) ea. Flat Washers S.S. (Input/Output Busbar Wiring) |
| (2) ea. 6-32 x 1-3/8" Phillips Screw (Finger Guard Cover) | (11) ea. 1/4" Split Lock Washers S.S. (Input/Output Busbar Wiring) |
| (2) ea. #6 23MM Spacer (Finger Guard Cover) | (5) ea. 1/4"-20 x 3/4" Hex Head Screws S.S. (Hot Switch Outputs) |
| (1) set Circuit Breaker Identification Labels | (1) ea. BBA-800 Bus Bar Assembly Kit (see BBA instructions for parts diagram) |
| (1) ea. Status Contact Wiring Harness with 3 position connectors | (1) ea. Installation/Operation Manual |
| (3) ea. 3 Position Terminal Block Connector for Summary, Pre-LVD and LVD Alarm Contacts | |

B) PFM Mounting

The PFM is designed for mounting in a 19" or 23" relay rack and occupies two rack-units (2RU; 3.5"). A 19" set of mounting ears and six 6-32 x 3/8" pan head phillips screws for attaching the ears to the PFM chassis are provided. Optional 23" rack mounting ears are available - please contact Newmar for P/N: 699-3918-0, qty 2. Attachment holes in the chassis are provided to allow either flush or 6" off-set or center mounting - rear support is required if choosing flush mounting.

C) Bus Bar Mounting

The PFM is shipped with a rackmount ground bus bar assembly kit (BBA-800). The bus bar is typically mounted on the rear of the rack and is designed for installation on 19" or 23" racks using the provided mounting brackets and isolated stand-offs. Refer to the instruction sheet provided with the BBA for complete mounting instructions and specifications.

BBA and PFM Rack Location Note: When wiring multiple power sources for parallel n+1 redundant wiring, equal length positive and negative conductors are required for optimum load current sharing. Mounting the BBA at the opposite end of the rack as the PFM (i.e., BBA at top-of-rack; PFM at bottom, or vice versa) will help facilitate equal length conductor wiring.

D) Input Voltage Selection (Universal) and Wiring

The PFM has a universal input so no input selection switch is required. It will operate on 12, 24, or 48V DC with positive or negative ground.

1) Simplified Wiring Option: DC Quick Connect Wiring Kit

A DC wiring harness quick connect kit is available from NEWMAR which simplifies parallel wiring installation of multiple Power Modules with the Power Function Manager, and also facilitates "hot change-out" of modules for repair or replacement. *Note: This option is available only for systems which incorporate 1,000 watt models of the NEWMAR PM Series Power Modules.*

The kit consists of a power wiring harness with wires which are pre-cut to proper length and properly terminated with ring lugs. The harness is neatly tie-wrapped into proper position for a simple and professional installation.

Two kits are available: QCK-3 for wiring up to three 24 or 48 volt Power Modules, and QCK-6 for wiring four to six 24 or 48 volt modules. For more information or to order the quick connect kit, please contact the factory. For 12 volt model PM-12-80, use model QCK-3A for up to three PM-12-80s and model QCK-6A for wiring four to six PM-12-80s.

Note: If using the QCK for Power Module/PFM wiring all Power Modules must be stacked in the rack, one atop another, above the PFM. (See FIGURES 3, 4 or 5)

2) Standard Wiring Instructions

Up to six power modules with the same voltage output may be wired to the PFM input, with the total load current not to exceed 500 amps.

Refer to FIGURE 3 for the PFM input wiring instructions which follow.

FIGURE 3: Typical PFM DC Input Wiring

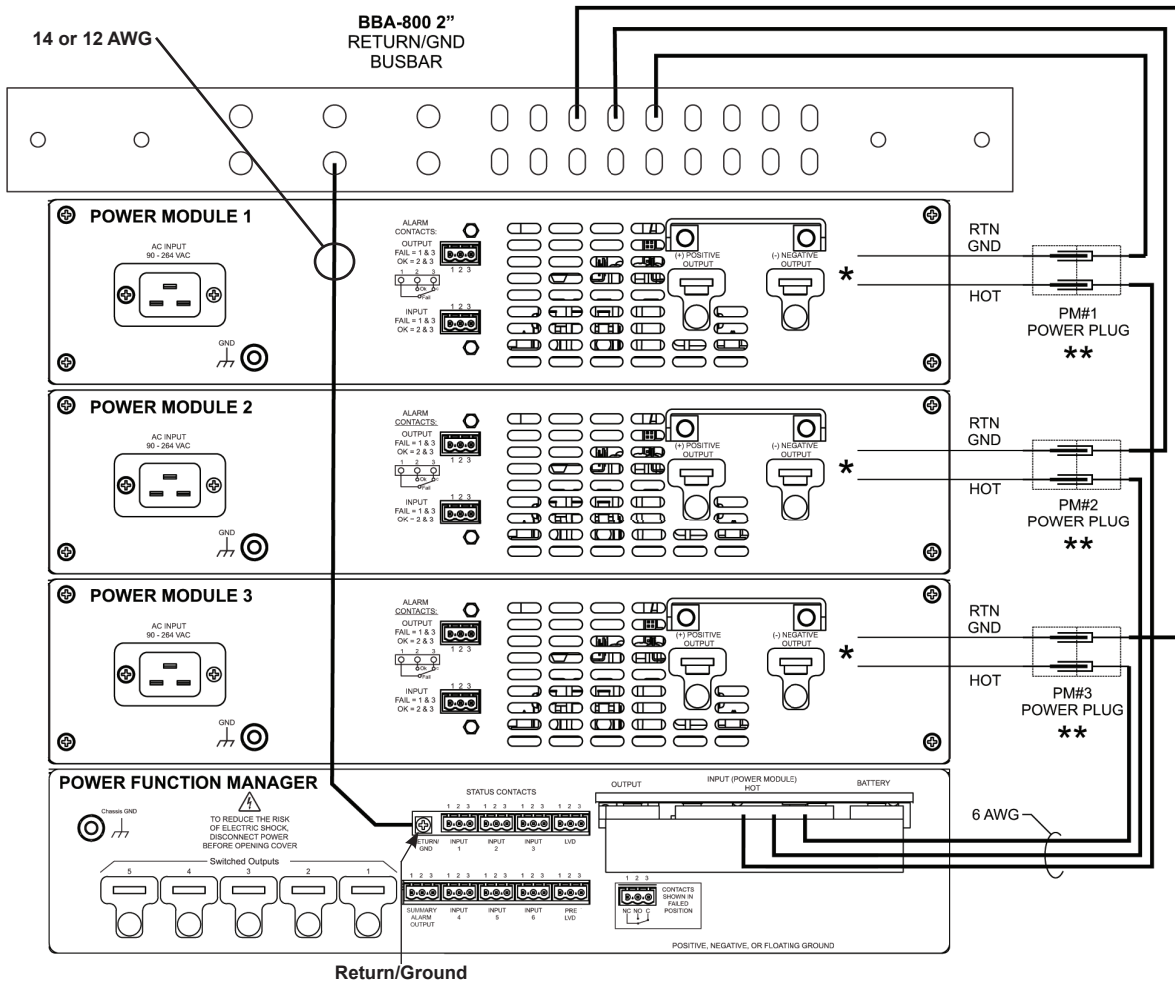

* Negative Ground Systems: Connect Ground Wire to (-) NEGATIVE OUTPUT Terminal and Hot Wire to (+) POSITIVE OUTPUT Terminal

* Positive Ground Systems: Connect Ground Wire to (+) POSITIVE OUTPUT Terminal and Hot Wire to (-) NEGATIVE OUTPUT Terminal

** Power Plugs shown present only if using NEWMAR QCK DC Quick Connect Kit, specify model QCK-3 (3 inputs) or QCK-6 (six inputs)

Figure 3 illustrates a typical input wiring configuration with three power modules and one PFM (either positive or negative ground system).

1) "Hot" input wires are attached to the heavy duty bus bar labeled "INPUT (POWER MODULE)" on the rear of the PFM. Use the provided 1/4" hex head screws-washer-net sets. These may be replaced with 5/16" hardware if required for the installation.

Wiring should be terminated with ring lugs to ensure a safe installation. The ring lugs must make direct contact with the bus bar. If more than four units are wired to the PFM, lugs may be doubled up on the posts by removing the post first, then reassembling the connection so that one lug seats against the bottom of the bus bar and the other against the top. Use an

additional stainless steel flat washer and lock washer set for proper installation of the second lug.

An elongated hole is provided directly behind the round hole to accommodate a second post for double hole wire lugs. This hole will accept either 1/4" or 5/16" hardware also and the rear post at each position is adjustable for center-to-center hole spacing between 3/4" and 1".

2) System or load ground wires are typically attached to the provided BBA bus bar, which has an assortment of hole sizes to suit most terminal requirements.

Refer to the output wiring recommendations of the instruction manual which accompanies the power modules for proper PFM input wire gauges.

3) A return/ground wire must also be run from the BBA bus bar (or other grounding point) to the terminal on the PFM labeled "RETURN/GND". This is not a system ground; rather, it is a reference ground for the PFM's volt/amp meter and low voltage battery disconnect. *Note: Do not confuse this post with the chassis grounding point on the left rear of the PFM. Wiring for the return/ground wire should be 12 or 14 AWG.*

Note: When paralleling multiple early model NEWMAR Power Modules (PM-12-70, PM-24-35, or PM-48-18), use (+) Positive and (-) Negative V OUT terminals only. Do not use V2 terminal.

E) Output Wiring

Output may be taken from a single unswitched output terminal or via up to five switched outputs. Installation of an optional circuit breaker (available from NEWMAR) is required for each switched output. (See section E Circuit Breaker Installation.) Refer to FIGURE 4 for the Output and Battery Wiring sections which follow.

FIGURE 4: Typical PFM DC Output and Battery Wiring

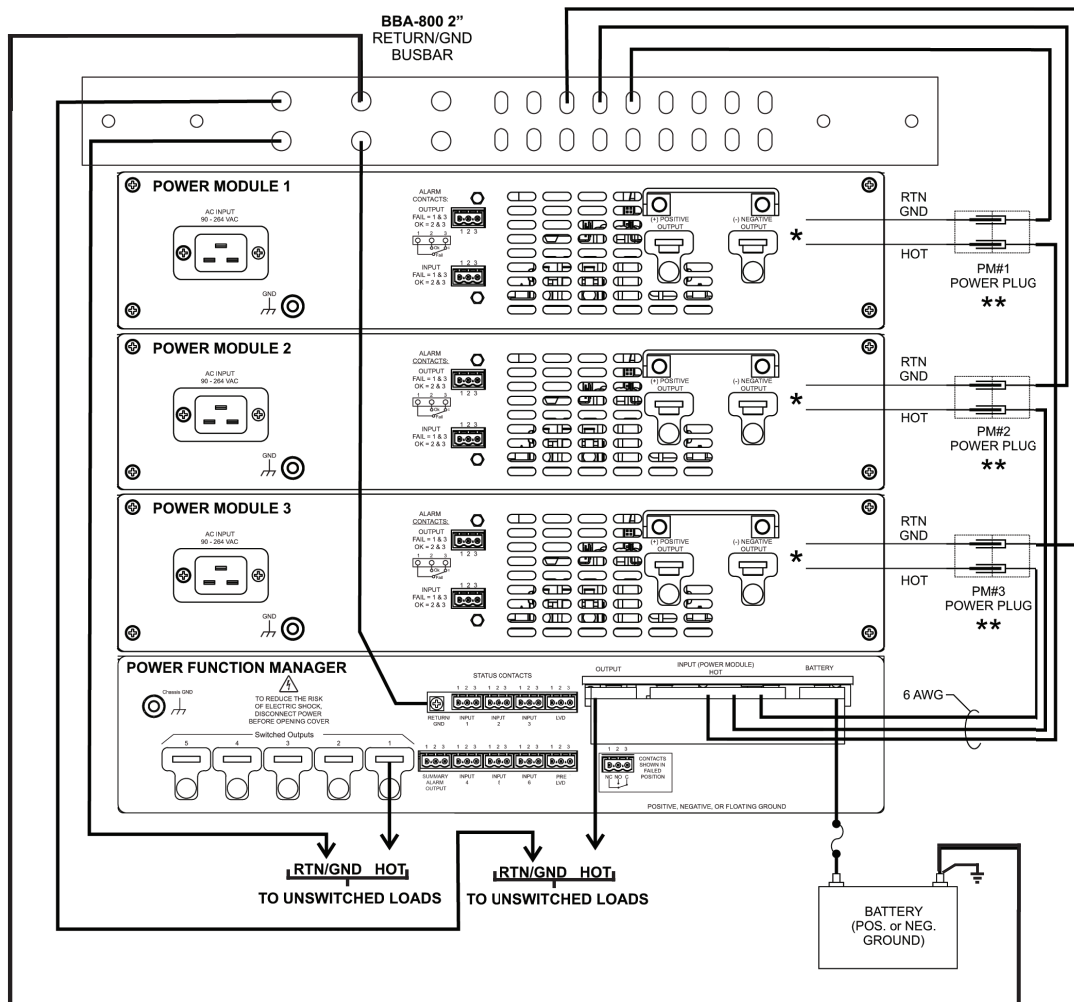

1) Unswitched Output

Use of the PFM unswitched output may be required under certain circumstances; for instance:

- * PFM output is routed through an external DC distribution panel
- * The load is in excess of 100 amps (maximum load through any switched output is 100 amps)

1) The hot load wire is attached to a 1/4" bolt-washer-nut set provided on the heavy duty bus bar labeled "UNSWITCHED OUTPUT" on the rear of the PFM.

The post hardware and bus bar hole configurations are identical to those on the "INPUT (POWER MODULE)" bus bar as described previously.

2) Use the chart below to determine minimum gauge for the output wire depending on the maximum load current and the length of the run from the PFM to the load or distribution bus (or refer to N.E.C. or local codes for any questions regarding proper DC wire gauges):

Note: Use this chart also to determine proper wire gauge for switched loads in the section following.

DC Wire Size Table:

Output Current Amps	Minimum Wire Size per N.E.C. AWG (mm)
up to 10	#16 (2mm)
11-20	#14 (2.5mm)
21-30	#12 (4 mm)
31-35	#10 (6 mm)
36-50	#8 (10 mm)
51-70	#6 (16 mm)
71-90	#4 (25 mm)
91-125	#2 (35 mm)
126-150	#1 (50 mm)
151-200	#0 (70mm)

Note: For applications in which a single wire will be required to carry more than 200 amps, refer N.E.C

To minimize line loss at lengths greater than 5 feet, it is recommended to increase wire size one gauge for each additional 5 feet of cable run.

2) Switched Outputs

Five switched output bus bars are provided for systems with multiple loads or where over-current protection/on-off switching at the PFM is required. Use of any of the switched outputs requires installation of a model 'PBA' plug-in breaker (available from NEWMAR) at that position. (See section II-I Fig. 7 for installation details and breaker functions. See section VII for available amperages and ordering guide.)

Wires are attached to the numbered output bus bars labeled "SWITCHED OUTPUTS". Terminate wires with 1/4" ring terminals to fit the attached posts.

Before wiring loads to the switched outputs make note of the following: The conductor for each breaker position runs straight through to the rear of the PFM so that the breaker in Position 1 (as you face the front) is on the far left, and the Position 1 output terminal (as you face the rear) is on the far right, and so on with each breaker/output terminal position reversed from front to back.

Refer to the DC Wire Size Table above to determine proper output wire gauges.

Note: 100 and 75 amp may not be installed side by side. There must be an open breaker position or a breaker rated at 50 amps or less between them.

F) Battery Wiring

The "HOT" (+) Positive or (-) Negative battery wire is attached to the heavy duty terminal labeled "BATTERY" on the rear of the PFM.

The terminal sizes and adjustability are identical to those of the "INPUT (POWER MODULE)" bus bar as described previously.

Prior to attaching battery wires ensure that the Low Voltage Battery Disconnect (LVBD) switch located on front panels is in the "MANUAL DISCONNECT" position. If it is not, use a ball point pen or similar object to move the recessed switch into this position. When in the disconnect position the LVBD contactor is forced open and the batteries are disconnected from the system, to ensure safe wiring. It is recommended that this switch be placed in the disconnect position whenever servicing

or making or breaking any connections to the batteries.

For safety, a fuse should be installed on the hot input/output battery wire, as close to the battery as possible.

Refer to the DC Wire Size Table to determine proper battery wire gauges.

G) Status and Summary & Pre-LVD Activation Alarm Contact Wiring

A color-coded status wiring harness for up to six sets of contacts has been provided with the PFM for ease of installation and to ensure proper connections. This harness is designed for installations which employ NEWMAR Power Modules, though it may be modified for use with other types of equipment, as well, provided they are equipped with Form C or Normally Open (N.O.) failure contacts.

All status contact connectors are for alarm inputs only and each is labeled INPUT. Two 3 position terminal block connectors are provided for the summary alarm output and the Pre-LVD alarm. The output of the PFM summary alarm and Pre-LVD alarms is Form C.

Refer to **FIGURE 5** below for the wiring instructions which follow.

FIGURE 5: Typical Status Contact and Summary Alarm Wiring

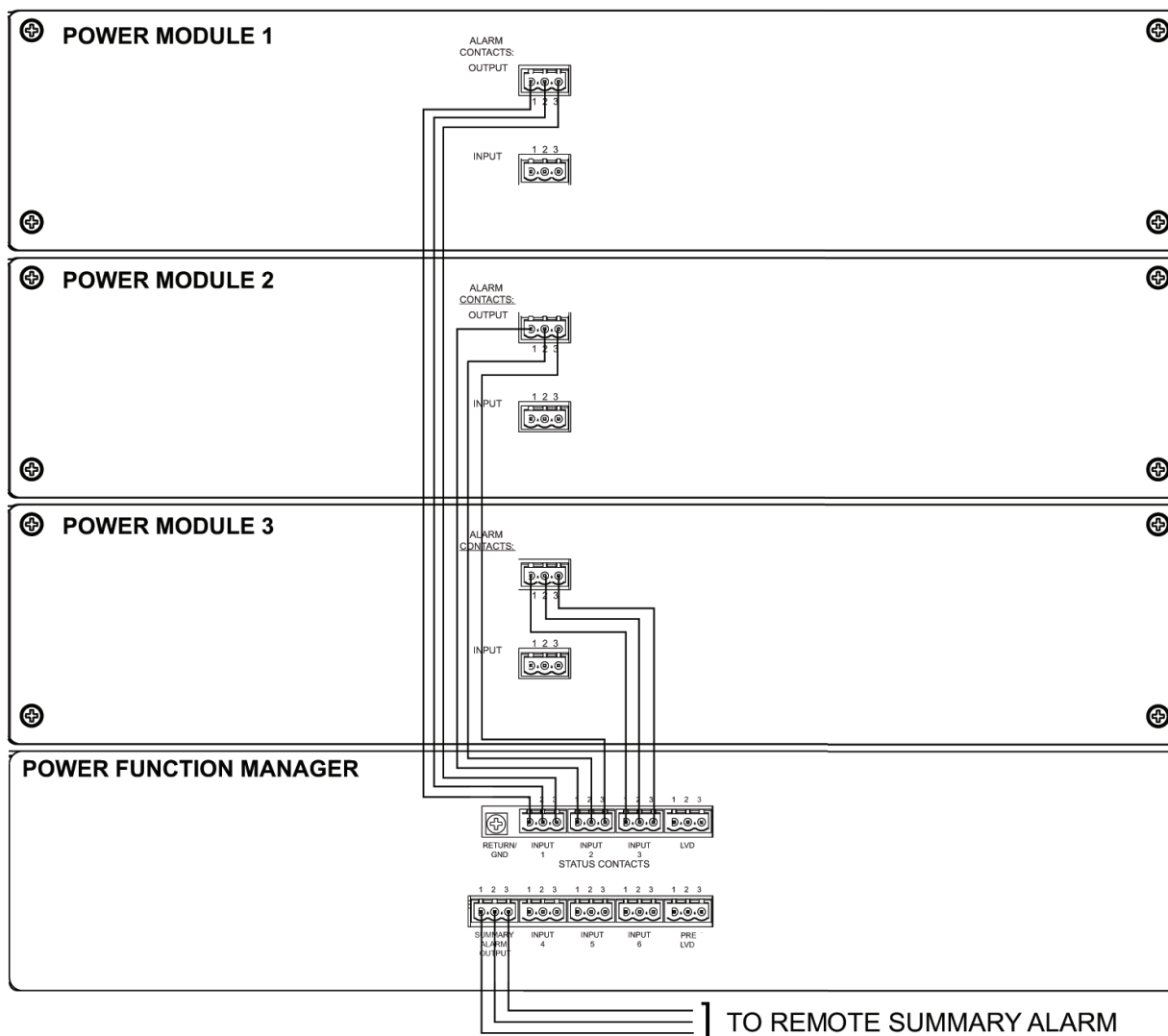

Note: This diagram depicts a system employing NEWMAR 2nd generation Power Modules, however, any equipment which utilizes Form C or Normally Open (N.O.) alarm contacts may be wired to the PFM's six Status Contact input connectors.

Status Contact Harness Connection

A typical system with three NEWMAR Power Modules is illustrated on the previous page. The provided status contact harness may also be used with non-NEWMAR equipment, however, it is likely that each connector on the harness which would normally plug into the power module will require removal and replacement with another suitable for that particular piece of equipment.

Careful attention to correct wire connections will be required when installing an alternate connector due to the uniform color of each wire group. Wiring from the alternate equipment contacts to the PFM contacts must be identical: (fail-to-fail, OK-to-OK) and Common-to-Common. "FAIL" and "OK" contact positions are illustrated on the rear of the unit beneath the Hot Output terminal. (Or see FIGURE 6, following.)

Alarm Wiring with NEWMAR DST-20A Distribution Panel

NEWMAR's DST-20A is provided with its own four-wire harness for alarm wiring. Plug one end of the harness into the keyed connector on the rear of the DST which is labeled BREAKER STATUS. Note: The harness is reversible, therefore it does not matter which end is plugged in. For PFM-500 use, cut off one Molex connector from the DST-20A harness and parallel the brown and blue wires. Parallel the orange and yellow wires. Select an un-used STATUS CONTACT Input and connect the parallel brown/blue wires to terminal #1 and the paralleled orange/yellow wires to terminal #3.

If all STATUS CONTACT positions are occupied (i.e., five or six Power Modules are in the system), and a summary alarm from the DST is required, this may be accomplished through parallel wiring of the status wires. Please contact the factory for information on how to perform this modification.

When wired to the PFM in this fashion any tripped breaker within the DST will result in illumination of the ALARM light on the front of PFM, as well as activation of the PFM summary alarm contacts.

Summary Alarm Wiring

The summary alarm contacts will be in the "FAIL" position under the identical conditions in which the "CHECK SYSTEM" indicator on the front panel is illuminated. (See Section III - B: Meter & Indicator for a complete description of failure conditions.)

This alarm may be wired with the relay "normally open" or "normally closed", as required for the installation. The position of the contacts during DC output failure and normal operating condition is illustrated below:

FIGURE 6: DC "FAIL" and DC "OK" Summary Alarm Contact Positions (as viewed from rear of chassis)

Note: The three right-hand connector positions are unused in this installation

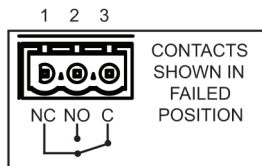

Relay contact rating for status and summary alarms is 5A @ 30V DC

H) Chassis Grounding

If grounding of the PFM chassis is required for the installation, use the provided 1/4" grounding stud on the rear panel identified as "CHASSIS GND" for this purpose. *Note: Do not confuse the chassis ground with the smaller return ground labeled "RETURN/GND", also on the rear panel of the PFM.*

I) Circuit Breakers

1) Circuit Breaker Installation

Circuit breakers must be installed to use any of the switched outputs. The PFM accepts only specially designed plug-in "mid-trip" circuit breakers with auxiliary contacts, which are available from NEWMAR. (The mid-trip function is explained later). Refer to the Specifications section for available breaker values and ordering info.

Refer to **Figure 7**, on the next page and install the plug-in circuit breakers as follows:

FIGURE 7: Circuit Breaker Installation

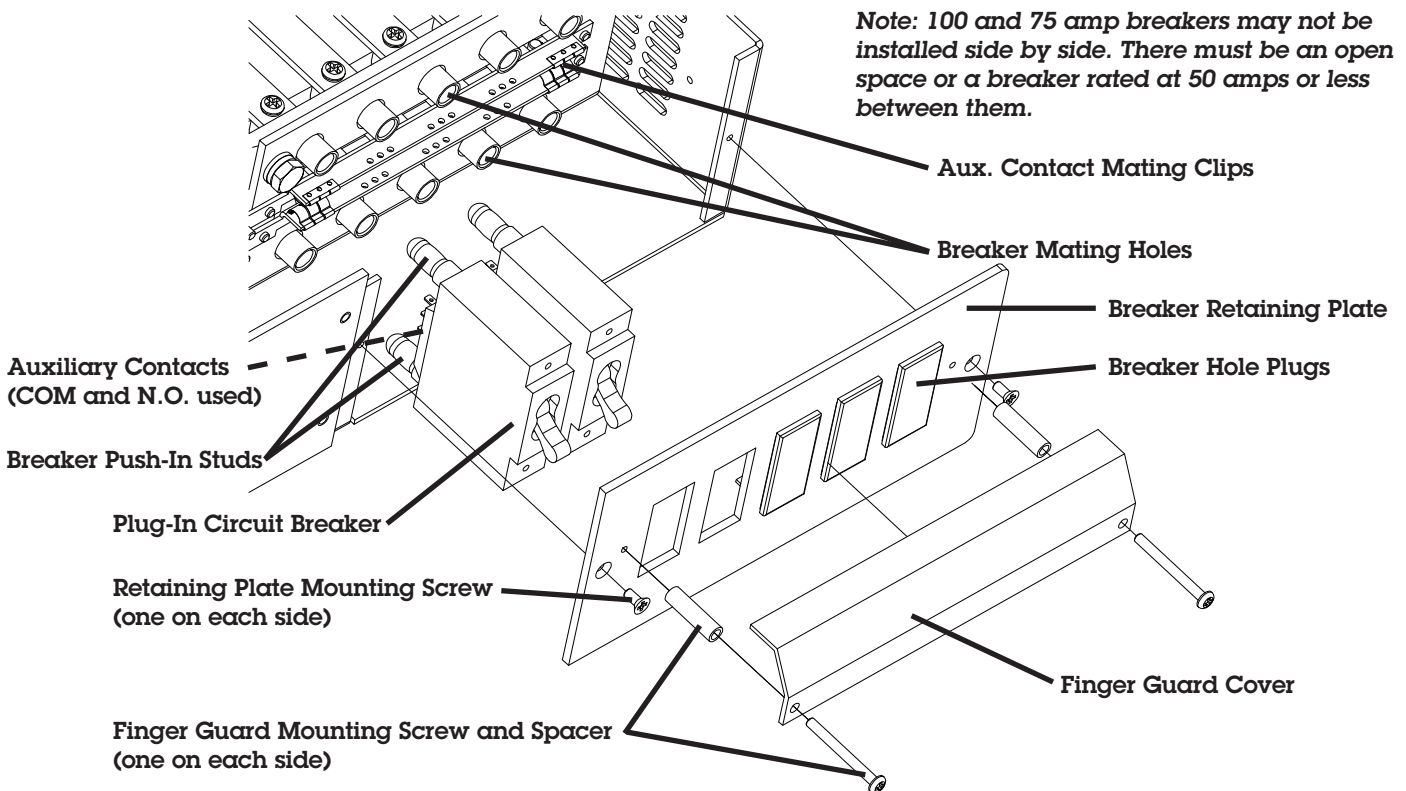

1) Shut off all power to the PFM and slide the LVBD switch on the front panel into the "MANUAL DISCONNECT" position before proceeding. Remove the two flat head screws on either side of the breaker retaining plate and pull firmly outward to remove it. *Note: The protective circuit breaker clear plastic toggle handle cover is not shown in the above diagram.* Installation is optional. If it has already been installed, it is not necessary to remove the cover in order to remove the retaining plate.

2) Remove the plastic breaker hole plugs as necessary.

3) *Prior to installing circuit breakers, make note of the following:* The conductor for each breaker position runs straight through to the rear of the PFM so that the breaker in Position 1 (as you face the front) is on the far left, and the Position 1 output terminal (as you face the rear) is on the far right, and so on with each breaker/output terminal position reversed from front to back.

4) Install each circuit breaker into the PFM with "OFF" facing upward (toggle down) by lining up the push-in studs of the breakers with the internal mating holes inside the breaker receptacle and pushing firmly into place. The two top auxiliary contact terminals in the middle of the breaker should press against the mating clips. The bottom auxiliary contact is unused in this installation.

5) Ease the breaker retaining plate back into position over the breakers and onto the PFM. The holes in the retaining plate are beveled to help adjust the breakers into position, but it may be necessary to retract the plate and nudge breakers individually to achieve the necessary alignment.

6) Replace the retaining plate mounting screws.

7) Restore power to the PFM (if all other aspects of installation have been completed) and return the LVBD switch to the "AUTO" position.

Circuit Breaker Finger Guard Cover, Labeling

Installation of the circuit breaker toggle handle finger guard cover is optional. Use the provided 6/32-1/4" screws and spacer for mounting the cover onto the retaining plate. Blank labels are provided with the packaging to be placed on the clear Finger Guard cover over each position for identifying each circuit function.

2) Circuit Breaker Function/Mid-Trip Feature

The plug-in circuit breaker functions as an on/off switch and provides over-current protection as rated. However, the special mid-trip feature allows the operator to distinguish between a condition where the breaker has been tripped by over-current and where it has been intentionally shut off.

When the circuit breaker is manually shut off, the summary alarm contacts within the PFM will remain in the "OK" position, to avoid setting off alarms unnecessarily when disconnect is intentional. When the breaker is tripped by over-current into the mid-trip position, the toggle handle will rest midway between the on and off positions, the PFM "ALARM" light will illuminate and the Form C summary alarm contacts will be in the "FAIL" position. (See Status Indicators section following.)

III) FRONT PANEL INDICATORS, DISPLAY AND SETTINGS

A) Settings

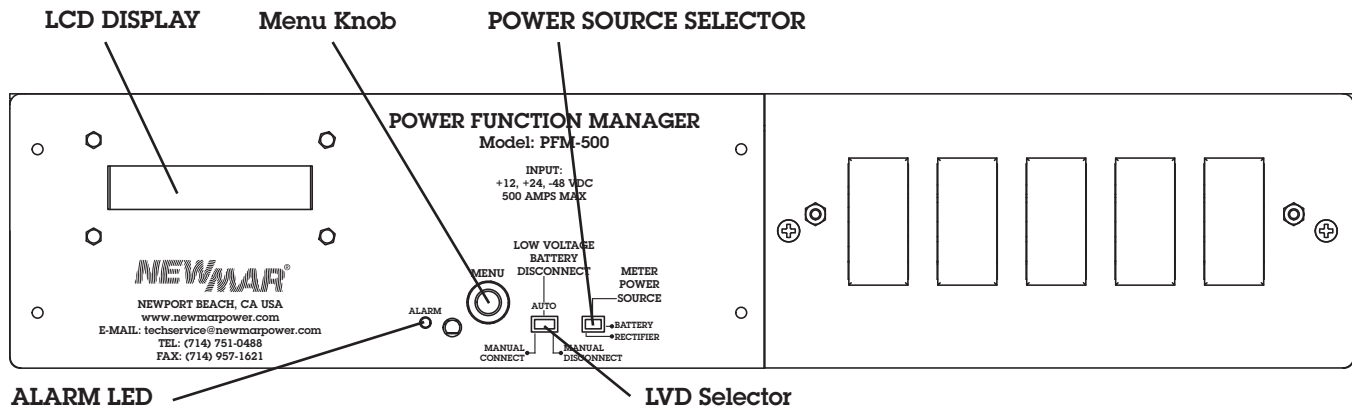

1) Meter Power Source Selector: The LCD meter can be powered from the rectifier side or the battery side by using the selector switch on front panel. Powering the meter from the rectifier side (default) causes the PFM-500 to completely shutdown during a Low Battery Voltage Disconnect thus reducing battery drain. Powering from the battery side will allow the LCD meter to continue operating even with a LVD disconnect event.

CAUTION: Moving the Meter Power Source Selector may momentarily remove power from meter causing a momentarily glitch in the meter display.

B) Indicators

1) Alarm LED on Front Panel: This red LED will illuminate when any of the following conditions occur:

- LVD Pre-disconnect threshold crossed (see Section III-A3 for more info)
- LVD activation- manually or automatically

2) Manual/Auto Selector Switch: The LVD selector switch, located on front panel, sets the way the LVD circuit functions.

- Manual connect - Battery always online
- Automatic - LVD function enabled (factory default)
- Manual disconnect - Battery always offline

C) LCD Display

1) Digital Meter Programming Sequence Flow Chart

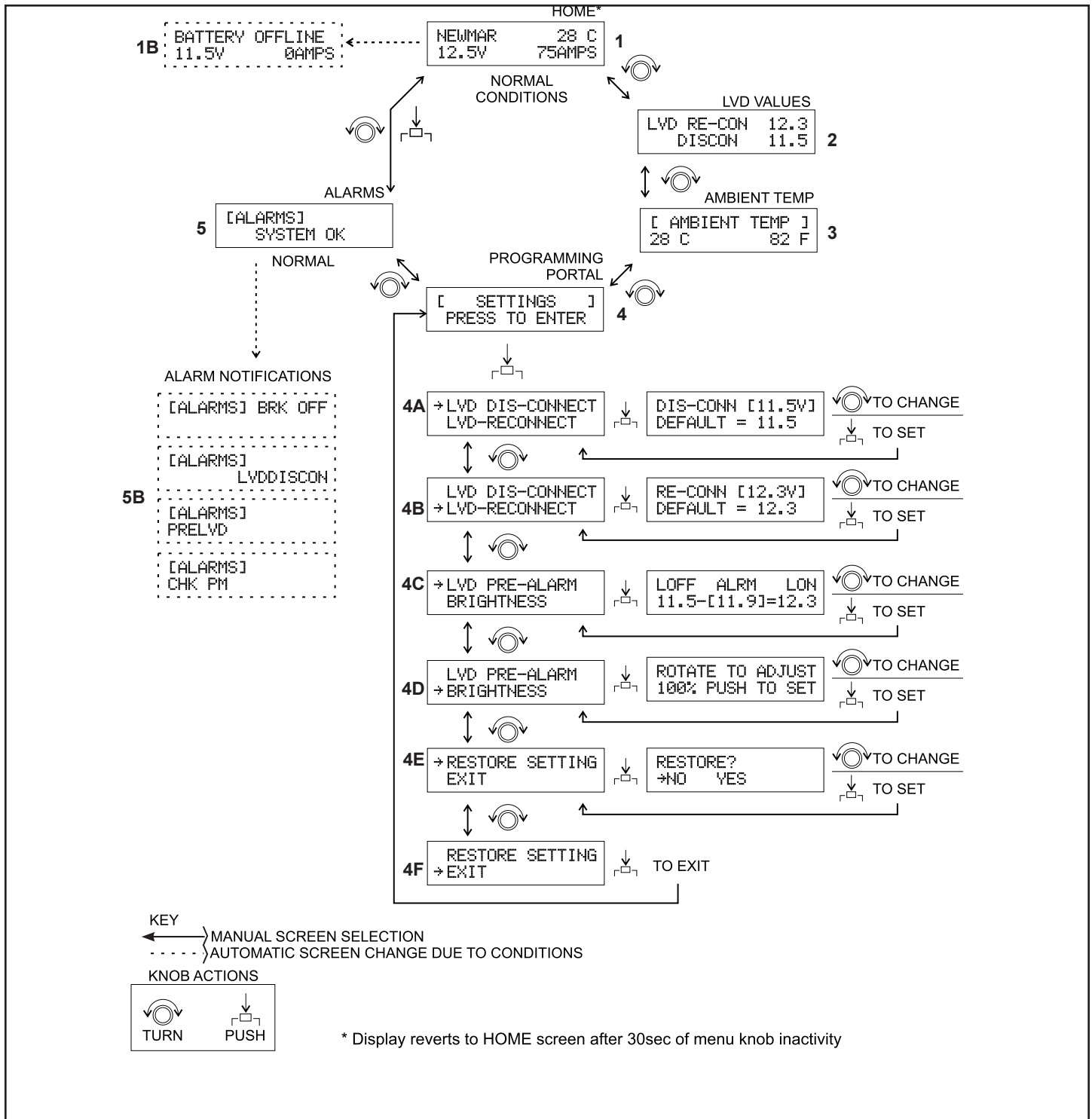

Figure 8: Digital Meter Programming Sequence Flow Chart - see page 12 for screen reference number detail

2) Digital Meter Programming Sequence:

Screen diagram reference number, corresponds to flow chart on page 11.

1) Home screen: displays DC voltage & total amperage consumed by system (loads and battery charge current), and temperature in degrees Celsius. When in programming mode the screen will revert to home after 30 second of inactivity. Note, it is normal the ammeter may toggle between 0 and 1 amp with no load or battery connected.

1B) If system battery is disconnected, screen will automatically display "Batt Offline" until battery is reconnected.

Rotating the knob will select other screens, or pushing the menu button will take you directly to the alarm screen.

2) LVD settings Screen: Displays the disconnect and reconnect voltages

Rotate knob to:

3) Ambient Temperature Screen: Displays temperature in degrees C and F.

Rotate knob to:

4) Programming Portal Screen: Displays when in 'ready to program' mode; push of menu button to move to programming screens, or rotating knob displays alarm screen (#5)

4A)->LVD voltage disconnect Screen, press programming button to enter set mode, rotate knob to change, push to confirm setting. See page 13 for detailed directions.

4B)->LVD voltage connect Screen, press programming button to enter set mode, rotate knob to change, push to confirm setting. See page 13 for detailed directions.

4C)->LVC pre disconnect voltage screen, press programming button to enter voltage at which pre trip alarm should activate, push to confirm setting. See page 13 for detailed directions.

Rotate knob to:

4D) Display brightness setting , press programming button to enter adjustment mode, rotate knob to change, push button to confirm

Rotate knob to:

4E) Restore factory setting screen, press programming button to access authorization screen, rotate knob to yes if you wish to apply factory global factory default settings, press programming button to confirm.

Rotate knob to:

4F) Exit screen, press programming button to return to Programming portal screen (ref #4)

5) Alarm system status screen: displays 'system ok' if no alarms have been tripped.

5B) If alarm conditions are present, screen will automatically display what alarm condition has occurred"

- BRK OFF= Breaker off
- LVDdiscon= Low voltage disconnect activated
- Prelvd= voltage approaching disconnect point, disconnect eminent.
- CHK PM= Summary alarm received from rectifier

Rotate knob to return to Home screen.

D) LVD Operation and Programming

Low Voltage Disconnect: The PFM-500 incorporates a 500 amp LVD circuit which automatically removes the battery when battery voltage drops to a pre-set DISCONNECT threshold (or when manually activated- see section 5.11) and automatically re-connects the battery when battery voltage rises above the selected CONNECT threshold (see Specification 8.0 for default LVD thresholds and adjustment ranges)

1) Manual/Auto Selector Switch: The LVD selector switch, located on front panel, sets the way the LVD circuit functions.

- Manual connect - Battery always online
- Automatic - LVD function enabled (factory default)
- Manual disconnect - Battery always offline

2) LVD Adjustment: The PFM-500 offers easy adjustment of both dis-connect and re-connect LVD settings without the need for an external, adjustable power supply. These thresholds can be selected on the front panel meter from the SETTINGS page (see Flow Chart on page 10) using the menu knob, the default factory setting for the particular item is also displayed. A press on the menu knob will save the settings and is retained even after powering down the unit. LVD threshold adjustment can be made while the system is operating.

3) LVD Alarms: Pre-disconnect & disconnect - Two external alarms can be triggered by the PFM-500: the Pre-disconnect ('PRELVD') and the LVD dis-connect ('LVDDISCON'). The LVD Pre-disconnect alarm is a warning to an impending battery disconnect. It is triggered by an adjustable voltage thresholds set above the LVD dis-connect threshold and below the re-connect threshold. The LVD dis-connect alarm is automatically set using the LVD dis-connect threshold (see 5.12). Both alarms will trigger the LED Alarm light.

4) LVD Voltage Sequencing Example - 12 VDC shown

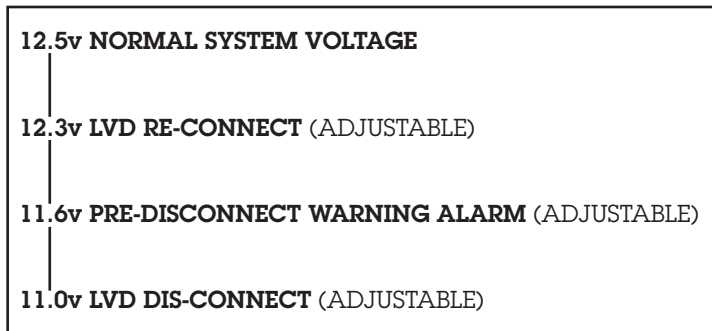

a) Normal Voltage: Typical system voltage with rectifiers supplying load(s), batteries not deeply discharged.

b) LVD Re-Connect: Level at which the battery will be re-connected after a dis-connect event when system voltage is restored.

c) Pre-LVD Alarm: Level at which the pre-LVD alarm contact triggers as an early warning for impending low battery disconnect. (See Specification Section 8.0 for factory default.)

d) Battery Dis-Connect: Minimum allowable battery voltage level has been reached and will disconnect battery to prevent damage. Will also trigger LVD alarm. (See Specification Section VI: Specifications for factory default.)

IV) TROUBLESHOOTING

PROBLEM

POSSIBLE CAUSE

CORRECTIVE ACTION

A. "ALARM" L.E.D. illuminated

1. Status contacts for one or more power modules or other monitored equipment mis-wired.

1. See Section II - G: Status and Alarm Contact Wiring for proper status contact wiring.

2. One or more Power Modules not outputting current.

2. Verify Power Module is wired correctly. See Power Module Installation/ Operation manual to verify proper operation.

3. LVD in disconnect position.

3a. Verify LVD switch is in the "AUTO" position.

3b. Check to see if battery voltage is below the LVD disconnect threshold. If so, remove load and recharge battery.

3c. Check to see if LVD disconnect voltage is set too high. See Section III-D for LVD adjustment procedure.

4. PFM load circuit breaker tripped. (Breaker is in mid-trip position.

4. Identify cause of over-current condition and reset breaker.

Note: Breaker will not activate the "ALARM" L.E.D. if manually switched into the off position.)

B. LVD contactor rapidly cycles between open and closed

LVD out of adjustment.

See section III-D for LVD adjustment procedure.

C. LVD disconnects battery from load too soon-batteries not low.

1. Disconnect threshold set too high.

1. See section III-D for LVD adjustment procedure.

2. Large voltage drop between (+) or (-) battery terminal and BATTERY HOT input post.

2. Shorten wire length and/or increase wire size. Check for loose connections.

3. Sudden voltage drop due to heavy intermittent load.

3. Increase battery capacity or test and replace batteries if necessary.

PROBLEM

D. LVBD will not connect battery to PFM although battery is fully charged.

POSSIBLE CAUSE

- 1. LVD out of adjustment.
- 2. LVD selector is in "MANUAL DISCONNECT" position.

CORRECTIVE ACTION

- 1. See section III-D for LVD adjustment procedure.
- 2. Reposition switch to "AUTO".

E) Meter Display Errors

LCD display gets out of sync with the micro-controller and displays incorrect information.

Power cycle the LCD. To power cycle the meter without disconnecting the load: first ensure the rectifiers are on, disconnect battery from PFM, then slide the meter power to 'Battery' then back to 'Rectifier'. This will briefly disconnect power to the meter and allow a safe power cycling and clear the display error. Reconnect battery to PFM.

F) LVD Stability Issues After Settings Change

LVD contactor cycles frequently after making changes to the LVD default settings

PFM-500 can be restored to factory settings to aid in troubleshooting (see section III page 12, item 4-4E and the Digital Meter Programming Sequence Flow Chart, page 11 for details).

Factory Contact Information

If a problem with the PFM-500 persists after you have applied the above-outlined solutions, or if you have any questions about the installation and proper operation of the unit, please contact NEWMAR's Technical Services Manager:

Phone: 714-751-0488 — From the hours of 7:00 A.M. to 4:30 P.M. weekdays, P.S.T.

Fax: 714-856-9679 — Anytime

E-Mail: techservice@newmarpower.com — Anytime

We are happy to consult with you to resolve any problems or questions you may have. If, during consultation, it appears the PFM must be returned to the factory for repair we will issue a Return Materials Authorization at that time.

V) SPECIFICATIONS

INPUT/OUTPUT: 12, 24 or 48V DC nominal; Positive or Negative Ground

VOLTAGE RANGE: 8 to 65 VDC

GROUNDING: Positive or Negative (Polarity insensitivity)

MAXIMUM TOTAL CURRENT CAPACITY: 500 amps (six power modules maximum)

PROTECTION:

- Up to five branch circuit breakers (optional)
- Low Voltage Disconnect (See LVD Specifications below)

INDICATORS/ALARMS:

- "ALARM" L.E.D. indicator (Red)
- Digital volt/amp meter
- Form C summary alarm contacts; provide for monitoring of up to six inputs from equipment with either
- Form C or Normally Open contacts. Typical indications include Power Module failure, LVBD activation, and breaker mid-trip condition
- Form C LVD pre-disconnect (see factory default LVD pre-disconnect alarm thresholds below)

TEMPERATURE RATING: 0° C to +60° C

CASE SIZE: H x W x D; 3.5" x 19" or 23" x 20.5"

LVD SPECIFICATIONS:

Factory set actuation voltages:

	12 Volt	24 Volt	48 Volt
Disconnect	10.4V DC	21.0V DC	42.0V DC
Connect	12.2V DC	24.5V DC	49.0V DC

FACTORY DEFAULT LVD PRE-DISCONNECT ALARM THRESHHOLD (Adjustable):

System Voltage	12V	24V	48V
LVD Pre-Disconnect	11.2V	22.8V	45.5V

VI) CIRCUIT BREAKER SPECIFICATIONS AND ORDERING GUIDE

Current Ratings: See chart below (breaker value stamped beside toggle)

Voltage Rating: 80 V d.c. max.

Type: Magnetic-Hydraulic Plug-in with Auxiliary Contacts (Normally Open) and Mid-Trip Function UL Listed Telecom Breaker CSA Certified Carries the CE Mark

To order additional or replacement breakers for the PFM-500 refer to the following NEWMAR model or Carlingswitch part numbers:

Rating	NEWMAR Model
5 amp	PBA-5
6 amp	PBA-6
10 amp	PBA-10
15 amp	PBA-15
20 amp	PBA-20
25 amp	PBA-25
30 amp	PBA-30
40 amp	PBA-40
50 amp	PBA-50
63 amp	PBA-63
75 amp	PBA-75
100 amp	PBA-100

Note: Other circuit breaker values are available on a special order basis. Typical lead time is 10 weeks.