

Rackmount Distribution Panel

Models:
DST-100/8 (DST-FB)

INSTALLATION/OPERATION INSTRUCTIONS

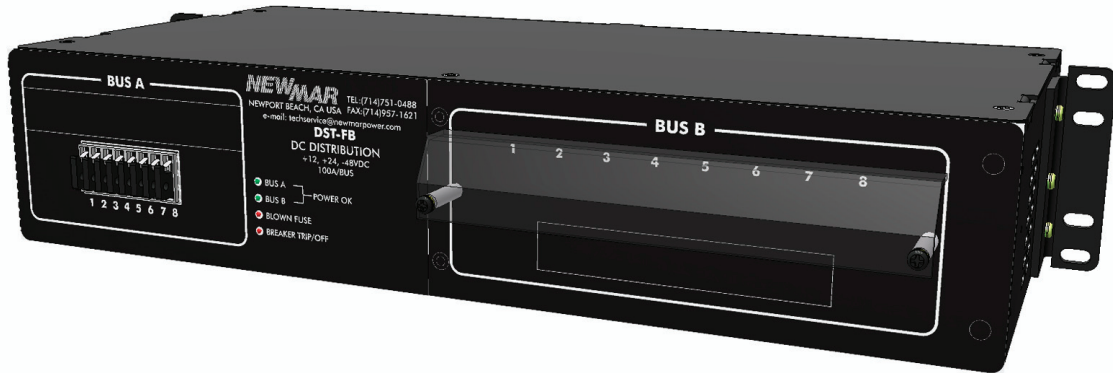

Note: This manual covers two identical model designations, DST-100/8 and DST-FB. Any reference to one applies to the other.

Table of Contents

Section	Topic	Page
I)	OVERVIEW	2
II)	IMPORTANT SAFETY INFORMATION	2
III)	MATERIALS LIST	2
IV)	PANEL INSTALLATION	2
	A) Panel Mounting	
	B) Input Wiring	
	C) Output/Load Wiring	
V)	FUSE, CIRCUIT BREAKER AND SUMMARY ALARM INSTALLATION	3
	A) Fuse Installation	
	B) Breaker Installation	
	C) Breaker Removal	
	D) Remote Summary Alarm Wiring	
VI)	INSTALLATION OPTION - Single 200 Amp Bus	4
VII)	FRONT PANEL STATUS LEDs	5
VIII)	SPECIFICATIONS	5
IX)	CIRCUIT BREAKER SPECIFICATIONS AND ORDERING GUIDE	5
X)	OUTLINE & MOUNTING DRAWING	6

M-DST-100/8(DST-FB)
011215



I) OVERVIEW

The DST-FB panel offers a unique combination of circuit protection, utilizing both circuit breakers and GMT fuses designed to accommodate virtually any communication site power distribution requirement.

The panel accommodates 8 GMT fuses and 8 circuit breakers (12, 24 or 48 VDC, positive or negative ground) within a compact housing occupying only 2 RU of rack space. The plug-in breakers only require front access for quick, easy installation during initial system configuration, as well as future system expansion.

Model DST-FB features dual isolated A and B buses, each rated at 100 amps, which accept up to 8 GMT fuses or 8 circuit breakers respectively and provide redundant power, dual voltage and/or dual ground reference configurations. The A and B inputs can also be paralleled to make a single 200 amp bus (see INSTALLATION OPTION Section VI).

Bus A accommodates GMT fuses which are available in numerous amperage ratings.

Bus B accommodates plug-in circuit breakers with compression power contacts which insert securely into sockets recessed in the panel.

Input/output wiring is via rear access barrier terminal blocks that accept single hole lugs.

Mounting brackets are provided to adapt the panel for 19" rack installation, flush or center mount (contact Newmar for 23" mounting ears). Snap-in hole covers are provided for unused breaker positions and a clear protective toggle guard is provided to prevent accidental breaker switching.

The panel is shipped standard without breakers or fuses. These are sold separately and are plugged into the unit during installation. Refer to the Circuit Breaker and Fuse Specifications and Ordering Guide section at the end of this manual for available values. The panel contains summary alarm contacts.

Warranty period for the panel is two years, parts and labor.

For questions or comments on Newmar Distribution Panels, please call 800-854-3006 or e-mail techservice@newmarpower.com.

II) IMPORTANT SAFETY INFORMATION

- 1) Never restrict air flow through the vents of the DST panel.
- 2) Reliable Earthing (Grounding) of rackmounted equipment shall be maintained.
- 3) The power connections shall be made with copper conductors.

Refer to NEC for proper dc wire gauge.

4) For use with Newmar DST-FB Series circuit breakers, special purpose, single pole, rated 65V dc, 5-30 amps, Orientated so that the ON position is in the UP position. (Suitable breakers are available from NEWMAR.)

III) MATERIALS LIST

Prior to installation, carefully review the following list to verify all necessary items have been provided. Note: Some items are provided in the hardware accessory package; others are taped to the main DST-FB assembly or installed. For any missing items please contact the factory. (Contact information may be found on the bottom of any page of this manual.)

Hardware/parts provided

- (1 ea.) Rackmount Distribution Panel Assembly
- (2 ea.) Mounting Brackets for 19" rack (stamped 13918C)
- (2 ea.) Input Parallel Jumper Bars
- (6 ea.) 6-32 X 5/16" Phillips Screws (for mounting bracket installation)
- (1 ea.) Molex-to-6 Wire Pigtail Connector Assembly (P/N 773-1210-0)
- (1 ea.) Molex-to-Molex 4 wire connector assembly (P/N 773-4000-1)
- (8 ea.) Open Circuit Position hole plugs (factory installed)
- (1 ea.) Clear Protective Toggle Guard (Bus B)
- (2 ea.) Toggle Guard Mounting Screws, 6-32 x 1 3/8"
- (2 ea.) Toggle Guard Nylon Stand-Offs
- (1 ea.) T-Block Cover, 4 position, clear
- (4 ea.) T-Block Cover, 8 position, clear
- (2 ea.) Flat Washers, # 6 (for toggle guard assembly)
- (8 ea.) Lock Washers, # 6 (2 ea. for toggle guard assembly; 6 ea. for mounting bracket installation)
- (3 ea.) Circuit Identification Label
- (1 ea.) White Ink Pen for Circuit Identification Label
- (1 ea.) Pen Holder (adhesive)
- (1 ea.) GMT Fuse Puller Tool
- (1 ea.) Installation/Operation Manual

IV) PANEL INSTALLATION

A) Panel Mounting

A set of mounting brackets are provided, and six 6-32 x 5/16" pan head phillips screws with six # 6 lock washers are provided for attaching the brackets to the assembly. Two sets of tapped attachment holes in the assembly sides facilitate either flush or 6" forward mounting.

B) Input Wiring

See **Figure 1** for Input and Output/Load Wiring. Hot and Return input power is Bus A and Bus B to the 1/4" stud terminals located near the center of rear panel. Each bus is rated at 100 amps and are electrically isolated permitting redundant power, dual voltage and/or dual ground reference configurations in the same unit.

Wiring should be terminated with 1/4" ring lugs to ensure a safe installation.

Recommended torque for all 1/4 inch hardware is 50 inch-pounds.

Figure 1: Input & Output/Load Wiring - Rear Panel View

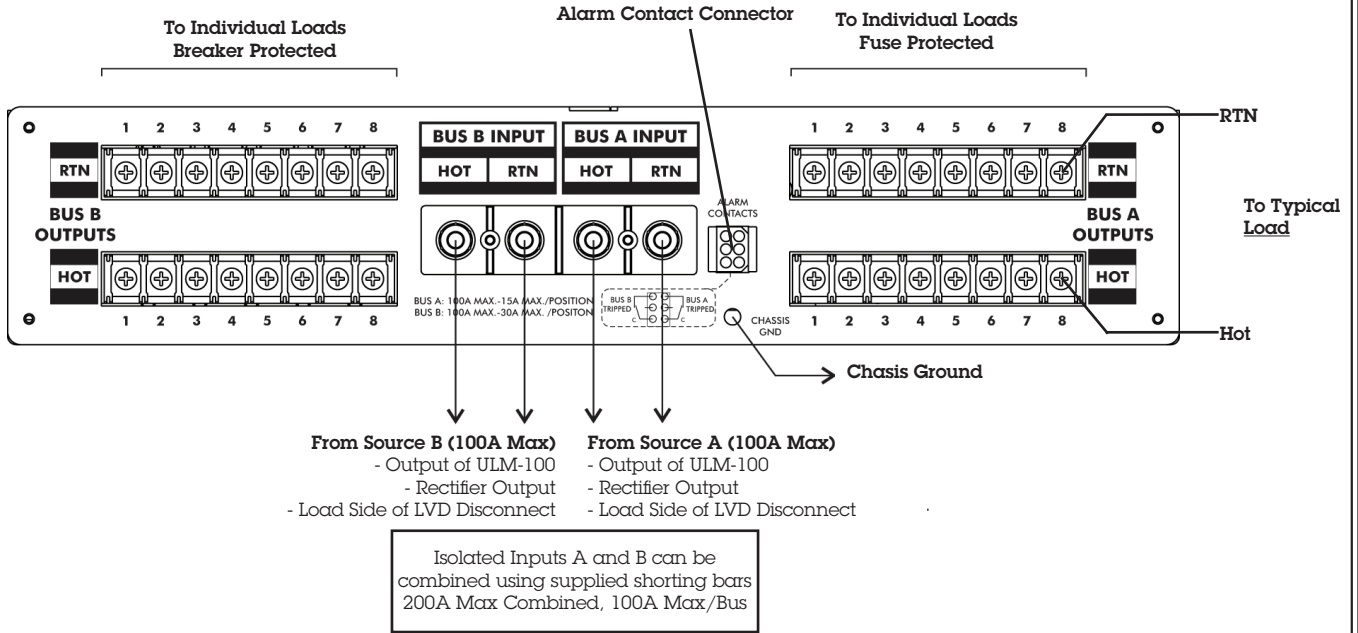

C) Output/Load Wiring

(Refer to N.E.C. or local codes for any questions regarding proper d.c. wire gauges and color codes.)

Sixteen pairs of output terminal screws are provided with model DST-FB. Use of any of the outputs requires installation of a plug-in DST-FB breaker or GMT fuse at that position. Fuse outputs 1-8 are fed by BUS A only; circuit breaker outputs 1-8 are fed by BUS B only (unless buses are paralleled).

Load wires are attached to the numbered output terminal block positions on panel rear.

Polarity Note:

System Voltage	Hot	RTN
-48 VDC	-	+
+24 VDC	+	-
+12 vdc	+	-

Note: The DST-FB is polarity in-sensitive. Either bus can be wired for positive or negative ground. Example: Bus A: -48 VDC, Bus B: +24 VDC.

Exception: when paralleling both Busses using the shorting bar in which case, both busses become same voltage and grounding.

V) FUSE, CIRCUIT BREAKER AND SUMMARY ALARM INSTALLATION

Figure 2: Fuse and Circuit Breaker Installation

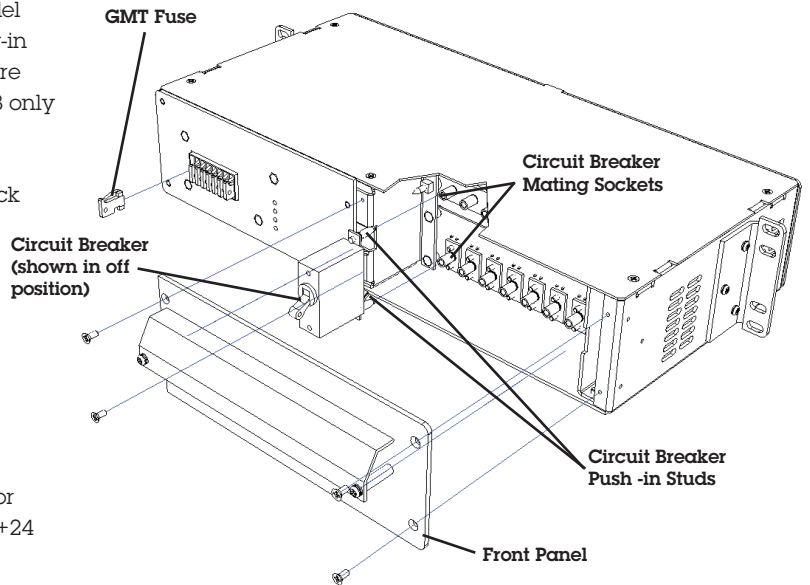

A) Fuse Installation

Bus A of the DST-FB accepts all GMT style fuse values, 15 amps and smaller. Line up the fuse as shown in **Figure 2** and press fuse into socket being careful not to damage the thin fuse element. Write in the fuse amperage and load powered on the self stick circuit I.D. label and affix to front panel. A fuse puller tool is provided to simplify fuse removal

B) Breaker Installation

The DST accepts only specially designed plug-in circuit breakers with auxiliary contacts which are available from NEWMAR. Refer

to the Circuit Breaker Ordering Guide at the end of this manual for available values.

Note: It is recommended that only breakers obtained from NEWMAR be used with this panel to assure proper fit and operation. Consult NEC for assistance in sizing breaker or fuse amperage to the load

- 1) Remove the front panel of the assembly (held in place with four flat-head phillips screws) and remove the plastic hole plug for the circuit breaker position being installed.
- 2) Install each circuit breaker by lining up the push-in studs of the breakers with the internal mating sockets and pushing firmly into place, see **Figure 2**.
- 3) Align the front panel into position over the breakers and onto the assembly.
- 4) Replace the front panel mounting screws.
- 5) Re-install plastic hole plugs in any unused breaker positions.
- 6) Remove the plastic film from the clear protective breaker toggle guard and install as shown in **FIGURE 3**.
- 7) Write in the breaker amperage and load powered on the self stick circuit I.D. label and affix to front panel.

FIGURE 3: Toggle Guard Installation

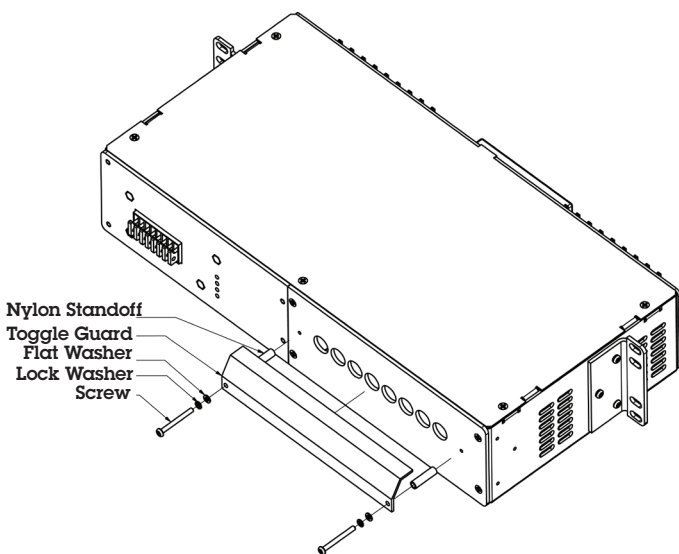

C) Breaker Removal

The front panel must be removed in order to remove any breaker. It is not necessary to remove the toggle guard in order to remove the front panel. Grip the top and bottom of the breaker with two fingers and pull breaker outwards while rocking up and down.

D) Remote Summary Alarm Wiring

A connector at the rear of the panel enables optional installation of a remote summary alarm to indicate when any fuse breaker

has been over-current tripped. Separate contacts are provided for each bus to activate Bus A and Bus B alarms independently, if desired. The alarm contacts are configured Form C: N.O. and N.C.. Diagrams on each side of the connector (labeled "Alarm Contacts") in the center of the rear panel illustrate the contactor positions when any breaker/fuse in the bus is in a TRIPPED/BLOWN state.

A six wire connector harness is provided for remote alarm indication (three wires for each bus). It is terminated with Molex connector at each end - see **Fig. 1**.

Wiring Options: Two molex connector assemblies are provided. Choose one depending upon your application

- 1) Molex -to-6 wire pigtail connector assembly (P/N 773-1210-0): Provides full wire connectivity to both Form C contacts on the DST-FB. Connect panel alarm contacts into site alarm/monitoring system.
- 2) Molex-to-Molex 4 wire connector assembly (P/N 773-4000-1): Designed to interface the DST-FB normally open alarm contacts to the Newmar Power Function Manager (PFM-400). Plugs into any unused input Status Contact Molex connector on PFM-400 rear panel. DST-FB fuse and circuit breaker alarm becomes a part of the PFM-400 'Check System'/Summary Alarm.

Power through the alarm contacts must not exceed the following:
1 amp @ 125 VAC
5 amps @ 30 VDC

VI) INSTALLATION OPTION - Single 200 Amp Bus

If the installation requires, the 100 amp A and B input buses may be paralleled to constitute a single 200 amp bus. This may be accomplished by paralleling the two Hot and two RTN input busses using the provided jumper brackets. See Single Bus Installation, see **Figure 4**.

Figure 4: Single Bus Configuration Using Parallel Jumpers

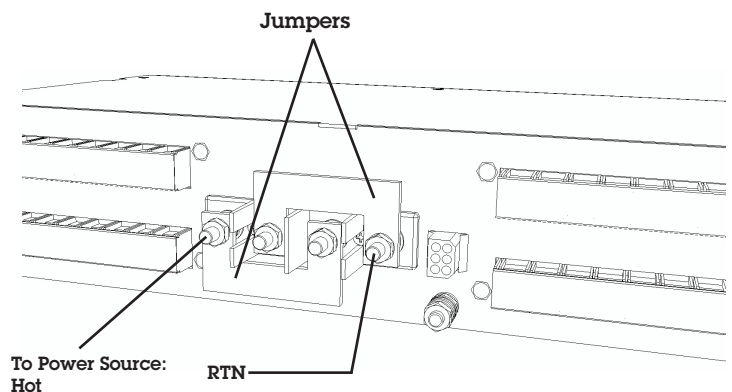

Note: The maximum total fuse/breaker current rating for positions 1-8 (BUS A) and positions 1-8 (BUS B) remains at 100 amps each, even when the two buses are wired in parallel.

VII) Front Panel Status LEDs

LED	Function
'BUS A/POWER OK'	GREEN when power is available on Bus A
'BUS B/POWER OK'	GREEN when power is available on Bus B
'BLOWN FUSE'	RED when installed GMT fuse is blown
'BREAKER TRIPPED/OFF'	RED when load connected but circuit breaker is in OFF position (or not installed)

VIII) SPECIFICATIONS

Electrical:

Nominal Input/Output:

48, 24 or 12 VDC; positive or negative ground

Total Circuit Capacity:

Bus A: 8 GMT Fuses, 15 amps max. per position, 100A max. total

Bus B: 8 Circuit Breakers, 30 amps max. per position, 100A max. total

Maximum Circuits per Bus: 8

Environmental:

Temperature Rating: 0 - 50° C ambient

Alarm/Indicator:

Tripped Fuse/Breaker Contacts via **Rear Panel Connector**; Form C

Note: Separate contacts are provided for each bus.

Maximum power through the alarm contacts:

1 amp @ 125 VAC

5 amps @ 30 VDC

Mechanical:

Terminal Blocks: Nickel-plated brass; accept single hole lugs or striped wire end placed beneath clamping plate

Front Panel: Powder coated aluminum

Cover and Rear Panel: Vinyl-laminated aluminum

Dimensions: 3.5" H x 17" W* x 11.75" D; Occupies 2 RU

*19" rack mounting brackets provided

Weight (without breakers): 5.5 lbs.

Warranty: Two Years

IX) CIRCUIT BREAKER AND FUSE SPECIFICATIONS AND ORDERING GUIDE

Current Ratings: See list below (breaker value stamped beside toggle)

Voltage Rating: 65 VDC max.

Type: Magnetic-Hydraulic Plug-in

3,000 Amp Interrupt Capacity

To order additional or replacement breakers for the DST-FB refer to the following NEWMAR model part numbers:

Rating	NEWMAR Model
5 amp	DST-FB-5
10 amp	DST-FB-10
15 amp	DST-FB-15
20 amp	DST-FB-20
25 amp	DST-FB-25
30 amp	DST-FB-30

Note: Other circuit breaker values less than 30 amps are available on a special order basis. Typical lead time is 4 - 6 weeks.



X) OUTLINE AND MOUNTING DRAWINGS - DST-FB

