



Powering The Network



Telecom



Wireless



iDAS/oDAS



Oil & Gas

Network DC Power Solutions:

Power Systems

Converters

NEW! DIN-Rail

Inverters

DC Distribution

Monitoring

Low Voltage Disconnects

Power Management

Batteries

Accessories



Powering The Network Solutions

AC-DC

Voltage/Power Range:

120/240V AC Input; 12, 24, 48V DC Output,
150 Watts - 14 kW

Components: Rectifiers, Battery Chargers, Power
Modules, Power Supplies, Power Management

Systems: Hot Swap Rectifiers Shelves with Distribution
and Monitoring

Power Plants: Rack Mount Systems with Batteries

DC-DC

Voltage/Power Range:

24 and 48V DC Input; 12, 24, 48V DC Output,
8 - 30 amps

Configurations: Rack Mount

DIN-Rail DC UPS & Power Supply

Voltage/Power Range:

115/230V AC Input; 12, 24, 48V DC Output,
10 amps

Configurations: DIN-Rail Mount

DC-AC

Voltage/Power Range:

24, 48 or 125V DC Input;
120/240V AC Output, 800 - 1600 Watts

Configurations: Rack Mount

DC Power Distribution

Voltage/Power Range:

12, 24, or 48V DC Input; 100 - 900 Amp VDC Output
Type: Circuit Breaker, Fuse, Automatic Re-Boot

Monitoring

Remote and Local Monitoring of 12, 24 and 48V DC;
DC Voltage, AC Voltage, Alarms, Batteries, Security,
Cameras. Remote Control of -48VDC Equipment

Type: Site Power Monitor, Circuit Breaker Distribution
with Remote Control

Low Voltage Disconnects

Voltage/Power Range:

12, 24, and 48V DC Input; 100 - 500 Amps
Configurations: Rackmount Mount



Hot Swap Rectifiers

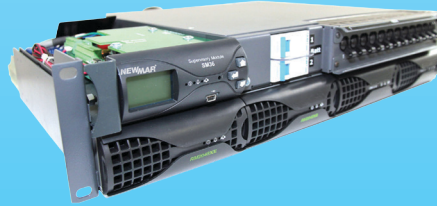

Hot Swap Rectifier System
with DC-DC Converter



DC-DC Converters

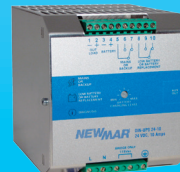

DIN-Rail



Inverters



Power Modules



DC Power Distribution



Remote Monitoring



Power Management &
Low Voltage Disconnects



Batteries
&
RPS Turnkey Systems
Available
(Contact Factory)

Unity Power System



The Unity Rectifier System comprises a low profile 1.75" (1 RU) shelf which accommodates up to three 150 watt, -48 or +24 volt hot swap rectifiers, plus an optional GMT fuse distribution panel which contains five individually fuse protected circuits. The system is scalable/adaptable for N, N+1 or N+2 configurations. Front panel test points and voltage adjustment pot are provided for fine-tuning output to the requirements of sensitive loads and to optimize load sharing. Form C status contacts enable remote alarms for the rectifiers and fuse distribution circuits. Front panel OK/FAIL LED's allow monitoring status of each rectifier individually. The optional power distribution module employs industry standard GMT fuses, configured with alarm contacts and a front panel "BLOWN FUSE" LED indicator.

Features

- 150 watt rectifier units - 48 or 24 volt, slide and lock into the Unity Shelf
- Shelf accommodates up to three rectifiers - 450 watts total - plus an optional five-position GMT fuse panel
- Scalable/adaptable hot swap configuration: N, N+1, N+2
- Front panel status indicators, output voltage test points and adjustment potentiometers
- Individual or summary rectifier alarm contacts; Form C
- Summary fuse panel alarm contacts; Form C
- Forced air cooling of rectifiers for extended component life
- 115/230 VAC shelf/rectifier input - easily adapts to available site power
- GMT fuse panel: Five positions, easy rear panel wiring to loads, fuse access at front
- Shelf adapts for 19" or 23" rack; center or flush mount (four-point cabinet mount optional)

Shelf	Input	Capacity	Size	Weight
URS	115/230 VAC Nom.	3 Unity Rectifiers (-48 or +24 V), 1 GMT fuse panel	19/23" Rackmount, 1 RU	6.7 lbs.

Rectifier	Input Amps @ Full Load 115/230V	Output Voltage	Output Amps Cont.	Watts	Size	Weight
UR48-3	2.2/1.1	-54.4 VDC, adjustable 42-56 VDC	3	150	1 RU	1.9 lbs.
UR24-6	2.2/1.1	+27.2 VDC, adjustable 21-28 VDC	6	150	1 RU	1.9 lbs.

GMT Panel	Nominal Input/Output	Total Fuse Fuse Capacity	Total Current Capacity	Size	Weight
UFP-5	-48 or +24 VDC	5	20A	1 RU	1 lbs.

Optional System Component



Unity Low Voltage Disconnect & Monitor

Digital battery monitor and alarm panel with Low Voltage Disconnect integrates with the Unity rack mount shelf into a highly functional power system. Built-in features include: LVD, digital monitor of voltage and amperage, battery disconnect breaker and alarm contacts. The digital display monitors bus voltage, battery voltage, system output current and low voltage connect/disconnect set points.

Model	Voltage Range	Max. Continuous Current	Low Voltage Battery Disconnect	Size	Weight
ULM-100	8 - 65 VDC	100 Amps DC	100 Amp, Solid State (FET)	19/23", 1 RU	6.25 lbs.



Powering the Network

Scout Power System

New!

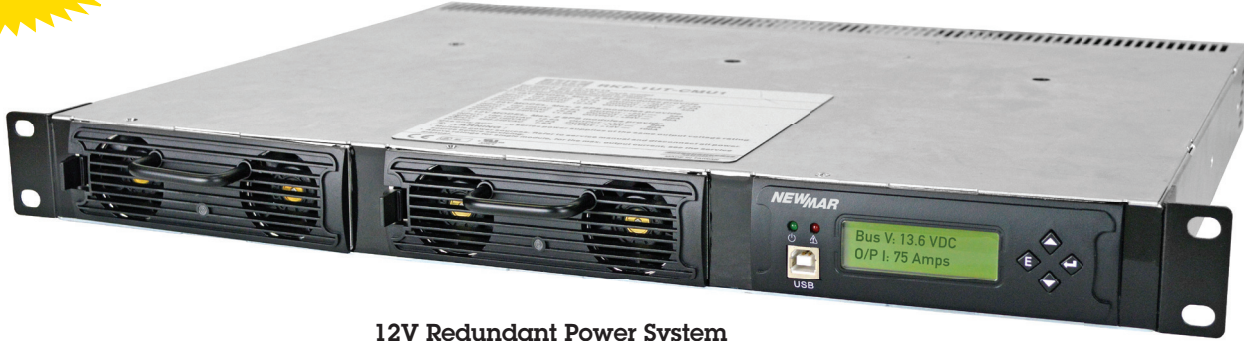

12V Redundant Power System

The Scout is a compact, high power density 12 volt rackmount power system that brings telecom power technology to 12 volt base station radio applications to power transmitters and maintain back-up batteries. Its dual 100 amp hot swap rectifiers configured in N+1 redundancy provides fault tolerant reliability. Remote monitoring capability provides system administrators with operating status.

Features

- Redundant hot swap rectifiers provide high system reliability
- Powers transmitters and maintains back-up batteries
- 100 amp output per module - 200 amp system capacity
- Controller module provides Web based remote monitoring and alarms, and LCD digital display of DC volts and amps
- Compact 1U rackmount shelf
- Optional LVD and power distribution shelf

Specifications

Input

Voltage: 90 - 264 VAC, 50 - 60 hz. via IEC C19/20 socket (x2)

Current (per module): 13 amps @ 115 VAC, 7 amps @ 230 VAC

Output

Voltage: 13.6 VDC, adjustable 10.5 - 14.0 VDC

Power (per module): 1200 watts, 100 amps @ 230 VAC input, 1140 watts, 95 amps @ 115 VAC input

Protection: Short circuit, overvoltage, current limit, over-temperature

Monitors

- LCD Digital Display: DC volt and current
- Remote via Ethernet
- DC ok via TTL
- AC fail
- Over-temp
- Fan fail

Operating Temperature: -40 to + 70° C

Mechanical: 19" rackmount, flush, 1RU, 13.75" depth

Safety Compliance: UL 60950

Input	# of Rectifiers Installed	
	1	2
230 VAC	100 Amps, 1200 Watts	200 Amps, 2400 Watts
115 VAC	95 Amps, 1140 Watts	190 Amps, 2280 Watts

Optional System Component: Low Voltage Disconnect, Circuit Breaker Distribution Shelf with DC System Bus/Tie Points Creates Complete Power System



PFM-500

Power Function Manager, 500 amps

Preliminary specifications subject to change without notice.



Powering the Network

Sentinel Power System

Smart Power



**Incredible Functionality, Scalability and Web Monitoring
in a 1 RU, 600 Watt to 1.8 Kw, 48V DC Power System**

- 19", 1U rackmount shelf with integrated power distribution and SNMP digital controller
- 90-250 VAC input, power factor corrected
- 3 power bays accept 600 watt modular rectifiers, -48V
- 33 amp, 1800 watt total max. output capacity
- Output temperature compensated for precise battery charging
- 4 DC circuit breaker distribution capacity, with tripped breaker alarm
- Master disconnect breaker for two battery strings, with tripped breaker alarm
- Controller with digital display of system parameters with TCP/IP Web interface and SNMP monitoring/logging
- Alarm contacts monitor major system functions
- General Purpose Digital Inputs for user configured external alarms
- Low voltage disconnect built-in
- Easily configures to meet site power requirements

Complete system design and assembly to your application parameters: rectifier configuration, distribution circuit breaker installation and programming of alarms and monitors. Installation in a relay rack with batteries and wiring also available.

Rectifier	Input Amps @ Full Load 115/230V	Output Voltage	Output Amps Cont.	Watts	Weight
RM-648	5.8/2.9	-54.4 VDC, adjustable 54 - 58 VDC	11A	600	1.9 lbs.

Shelf	Input Voltage Range	Configuration	Size	Weight
SRS-48	90-300V, 45-65 Hz.	3 Sentinel Rectifiers (-48 V bays), Controller, 4 DC Circuit Breaker Distribution, 2 x 30A Battery Breakers	19/23", 1 RU	19.84 lbs.

* 23" adapters required, model SRS-1U

Smart Power Features

Newmar power systems embed the latest technology in smart software to provide the ultimate in intelligent system functionality.

Elements include:

- **Smart Set-Up:** An extensive menu of system parameters for customization per site
- **Smart On-Site Data Viewing:** All system data accessible on-site by laptop via USB
- **Smart Viewing by Web:** Voltages, load, and battery performance data (Ethernet, RJ45)
- **Smart Automatic System Adjustments:** Temperature Compensated charging, low voltage disconnect, battery equalization, fast charging
- **Smart Alarm Notifications:** Voltage, temperature as well as several user defined

General Specifications

AC Input

Nominal: 115 or 230VAC (power cord with NEMA-5-20 plug attached)

DC Distribution

Load: 4 breaker position capacity, available amperages (specify) 6A, 10A, 20A, 30 amp, with tripped breaker alarm

Battery: 2 x 30A battery circuit breakers, with tripped breaker alarm

Low Voltage Battery Disconnect: 80A battery LVD installed, with disconnect alarm



Powering the Network

Centurion II Power System

Smart Power



Incredible Functionality, Scalability and Web Monitoring in a 2 RU, 1.0 to 6.0 Kw, -24/48V DC Power System

- 19", 2U rackmount shelf with integrated power distribution
- 90-250 VAC input, Power Factor Corrected
- 3 power bays accept 1000 or 2000 watt modular rectifiers
- 111 amp, 6000 watt total max. output capacity, (74 Amp, 4000 Watt, N+1) @ - 48 VDC
- Output temperature compensated for precise battery charging
- 16 DC circuit breaker distribution capacity, with tripped breaker alarm
- Master disconnect breakers for two battery strings, with tripped breaker alarm
- Controller with digital display of system parameters with TCP/IP Web interface and SNMP monitoring/logging
- Alarm contacts monitor major system functions and dry contacts for user programmable alarms
- General Purpose Digital Inputs for user configured external alarms
- Low voltage disconnect built in
- Easily configures to meet site power requirements

Complete system design and assembly to your application parameters: rectifier configuration, circuit breaker installation, and programing of alarms and monitors. Installation in a relay rack with batteries and wiring also available.

Rectifier	Input Amps @ Full Load 115/230V	Output Voltage	Output Amps Cont.	Watts	Weight
C2R-1000	@ <175 VAC = 6.2A	-54.4 VDC, adjustable 48 - 58 VDC	18A*	1000	3.5 Lbs.
C2R-2000	@ <175 VAC = 12.5A	+27.2 VDC, adjustable 24 - 29 VDC	37A*	1000	3.5 Lbs.
C2RX-2048	@ <175 VAC = 12.5A	-54.4 VDC, adjustable 48 - 58 VDC	37A*	2000	3.5 Lbs.

* @ 120 VAC: Derate 2 kW rectifiers 41%; 1kW rectifiers 33%

Shelf	Input Voltage Range	Configuration	Size	Weight
C2RS-24	90-300V (derate @ 115 input), 45-65 Hz.	3 Centurion II Rectifiers (+24 V), Controller, 16 DC Circuit Breaker Distribution, 2 x 100A Battery Breakers	19/23", 2 RU	19.84 Lbs.
C2RS-48		3 Centurion II Rectifiers (-48 V), Controller, 16 DC Circuit Breaker Distribution, 2 x 100A Battery Breakers		

General Specifications

Input

Nominal: 230V

Voltage Range: 90 - 300V (derate @ 115 input)

Frequency Range: 45 - 65 Hz

Power Factor: >0.99

Efficiency: >94% (from 30-95% output power)

Current Draw @ 230 VAC: 1000W Rectifier: 4.6 Amps
2000W Rectifier: 9.2 Amps

Environmental

Ambient Temperature: Nominal: 25+/-5° C

Range: -10° C to +70° C (maximum output power is derated above +50° C)

Humidity: 5-95% RH (non-condensing)

Altitude: <8,202 ft., De-rate maximum ambient temperature by 4° C per 3,280 ft. above sea level

The Centurion II Power System features Smart Power, see page 3 for more information.



Powering the Network

Centurion III Power System

Smart Power



Power -48, 24 and 12 Volt Site Equipment from One System with Web Monitoring.

- 19", 2U rack mount shelf with integrated power distribution
- 90-250 VAC input, Power Factor Corrected
- 2 power bays accept 1000 or 2000 watt modular rectifiers
- 74 amp, 4000 watt total max. output capacity, (37 Amp, 2000 Watt, in N+1 configuration) @ - 48 VDC
- 2 power bays accept DC-DC modules
 - -48V to 12V and -48V to 24V
- Output temperature compensated for precise battery charging
- -48VDC: 10 circuit breaker distribution capacity with tripped breaker alarm
- 1 each DC-DC converter output circuit breaker distribution with tripped breaker alarm
- Master battery disconnect breakers (63 amps) for two 48 volt strings, with tripped breaker alarm
- Controller with digital display of up to three system DC system parameters with TCP/IP Web interface and SNMP monitoring/logging
- Alarm contacts monitor major system functions
- General Purpose Digital Inputs for user configured external alarms
- Low voltage disconnect built in
- Easily configures to meet site power requirements
- Controller provides alarms for both rectifiers and DC-DC converters

Complete system design and assembly to your application parameters: rectifier and DC-DC configuration, circuit breaker installation, and programming of alarms and monitors. Installation in a relay rack with batteries and wiring also available.

Rectifier	Input Amps @ Full Load 115/230V	Output Voltage	Output Amps Cont.	Watts	Weight
C2R-1000	@ <175 VAC = 6.2A	-54.4 VDC, adjustable 48 - 58 VDC	18A*	1000	3.5 Lbs.
C2RX-2048	@ <175 VAC = 12.5A	-54.4 VDC, adjustable 48 - 58 VDC	37A*	2000	3.5 Lbs.

* @ 120 VAC: Derate 2 kW rectifiers by 41%; 1kW rectifiers by 33%

DC Converter	Input Voltage Range	Output Voltage Range	Output Amps Cont.	Watts	Weight
C3C-12-40	40 - 60 VDC	11 - 14 VDC	40A	560	3.5 Lbs.
C3C-24-25	40 - 60 VDC	22 - 26 VDC	25A	560	3.5 Lbs.

Shelf	Input Voltage Range	Configuration	Size	Weight
C3RS-48-124	90-300V (derate @ 115 input), 45-65 Hz.	2 Centurion III Rectifiers (-48 V), 2 Centurion III DC-DC Converter Modules (48 to 12 V and/or 48 to 24V), Controller, 10 DC Circuit Breaker Distribution, 2 x 63A Battery Breakers	19/23", 2 RU	19.84 lbs.

The Centurion III Power System features Smart Power, see page 3 for more information.



Powering the Network

Commander Power System

Smart Power



Incredible Functionality, Scalability and Web Monitoring in a 5 RU, 1.0 to 14.0 Kw, -48V DC Power System

- 19", 5U rackmount shelf with integrated power distribution
- 90-250 VAC input, Power Factor Corrected
- 7 power bays accept 1000 or 2000 watt, -48V modular rectifiers
- 259 amp, 14,000 watt total max. output capacity, (222 Amp, 2,000 Watt, N+1) @ - 54 VDC
- Output temperature compensated for precise battery charging
- 18 DC circuit breaker distribution capacity, with tripped breaker alarm, 63 amp max. circuit breaker rating
- Master battery disconnect breakers for four battery strings, with tripped breaker alarm
- Controller with digital display of system parameters with TCP/IP interface and SNMP monitoring/logging
- Alarm contacts monitor major system functions and dry contacts for user programmable alarms
- General Purpose Digital Inputs for user configured external alarms
- Low voltage disconnect built-in
- Easily configures to meet site power requirements

Complete system design and assembly your application parameters: rectifier configuration, distribution circuit breaker installation, and configuration of alarms and monitors. Installation in a relay rack with batteries and wiring also available.

Rectifier	Input Amps @ Full Load 115/230V	Output Voltage	Output Amps Cont.	Watts	Weight
C2R-1000	18/12	-54.4 VDC, adjustable 48 - 58 VDC	18A*	1000	3.5 Lbs.
C2RX-2048	37/21	-54.4 VDC, adjustable 48 - 58 VDC	37A*	2000	3.5 Lbs.

* @ 120 VAC: Derate 2 kW rectifiers by 41%; 1kW rectifiers by 33%

Shelf	Input Voltage Range	Configuration	Size	Weight
CMDRS-48	90-300V (derate @ 115 input), 45-65 Hz.	7 Commander Rectifiers (-48 V), Controller, 18 DC Circuit Breaker Distribution, 4 x 100A Battery Breakers	19/23", 5 RU	35.15 Lbs.

General Specifications

DC Distribution

Load: 18 breaker position capacity, available amperages (specify) 6A, 10A, 16A, 20A, 25A, 32A, 40A, 50 and 63A tripped breaker alarm

Battery: 4 x 100A battery circuit breakers.

Breaker Fail Detection: Electronic fail detection on both load and battery breakers

Low Voltage Battery Disconnect: 300A battery LVD installed standard, with disconnect alarm

The Commander Power System features Smart Power, see page 3 for more information.



Powering the Network

Power Modules

These versatile Rectifier Modules function as either power supplies or battery chargers for 12, 24 or 48 volt systems; positive, negative or floating ground. They may be employed singly or in combination, enabling the installer to scale the system anywhere from 500 to 10,000 watts per rack. Units may be paralleled for N+1 redundancy and alarm contacts allow local or remote monitoring. An optional DC quick connect wiring kit allows easy replacement of modules without system shutdown.



Power Modules may be used separately as a power source, or they may be integrated with the Power Function Manager, model PFM-500.

Features

- 12, 24 or 48 volts output; pos., neg. or floating ground
- Built-in oring diode for parallel or N + 1 configuration
- Power supply or battery charger operation (DC UPS system)
- Optional battery charging circuit: three-step charging, gel/lead-acid switch, and temperature compensation
- Form C alarm contacts



Power Modules integrated with Power Function Manager in complete system, see page 19 for more information

Model	Input Amps @ Full Load 115/230V	Output				Dimensions (H x W x D) Inches	Weight	
		VDC V Out	VDC V2	Amps Cont. +	Watts		Lbs	Kg.
PM-12-40	8.5/4.3	13.6	14.3	40	560	3.5 x 17 x 20.5	12.2	5.5
PM-12-80	16/8	13.6	—	80	1000		15.2	6.9
PM-24-20	8.5/4.3	27.2	27.9	20	560	19" mounting brackets provided	12.2	5.5
PM-24-40	16/8	27.2	—	40	1000		15.2	6.9
PM-48-10	8.5/4.3	54.4	55.1	10	560		12.2	5.5
PM-48-20	16/8	54.4	—	20	1000		14.0	6.4
PM-48-50	*/22	54.4	—	50	2200		34	15

VDC (V out) Measured at output terminal with oring diode
 * 230 VAC input only
 VDC (V2) Measured at direct output terminal
 + For parallel configuration/load sharing derate output 10%

Specifications

Input:

- 85 - 135/170-270 VAC (selectable), 47 - 63 Hz., 560 watt models
- 90 - 265 VAC, 1000 watt models
- 207 - 253 VAC, 2200 watt model

Power Factor:

560W & 2200W models: 0.7
1000W models: 0.98

Regulation: ± 1% at direct output (V2); ± 2% through "oring" diode (V out)

Ripple: 1% (Typical)

Efficiency: 80-85% @ full load

Front panel Output Voltage Adjustment Pot Range: ±10%

Altitude Range: Full output to 5,000 feet. Derate output current 4% per 1,000 feet to 10,000 feet max.

Temperature Rating

560 watt models: -40° C to +60° C; Derate linearly from 100% load @ 50° C to 75% @ 60° C

1000 watt models: -20° C to + 70° C; Derate linearly from 100% load @ 50° C to 50% @ 70° C

2200 watt model: 0 - 50° C



Powering the Network

Integrated Power Systems

The Integrated Power System (IPS) is a unique multifunction power supply which incorporates built-in battery back-up and numerous power accessories within a single 2RU (3.5") chassis, thus eliminating time-consuming system integration, component sourcing and installation, while saving precious rack space—ideal for any low-to-medium power application requiring AC fault tolerant operation.



A precision regulated power supply/charger, back-up battery, low voltage battery disconnect, output metering, LED status and Form C alarm contacts are all pre-wired and calibrated within the unit for plug-and-play operation. Plug-in terminals are provided for easy wiring of an additional parallel rectifier input, or external batteries for increased back-up capacity.

The batteries are always in-line with the load, thus there is no interruption from relays or transfer switches in the event of AC loss. Batteries are recharged when AC is restored. A manual battery disconnect switch allows internal or external battery service or replacement while the system is running. Models available for -48, +24 and +12 volt applications.

Features

- Precision regulated power supply simultaneously maintains batteries at peak charge and supplies system load
- Built-in batteries instantly power load during AC failure - no switch-over delay. 3 - 5 year average life. Terminals provided for additional external batteries for increased back-up capacity
- Terminals provided for easy addition of parallel rectifier. (48V and 24V models only)
- Automatic low voltage and manual battery disconnect
- Numerous front panel monitors--L.E.D. status indicators and digital ammeter/voltmeter
- Form C summary failure alarm contacts; loss of internal rectifier output, loss of external rectifier output, LVBD contactor open. AC input failure alarm contacts optional
- Numerous protection features--AC input breaker, internal battery breaker, auto thermal shutdown/recovery, current-limiting, short-circuit and over-voltage protection.
- 19" or 23" rack mount, flush or 6" forward mounting

Models	Input Amps @ Full Load 115 / 230	Output			Internal Battery Capacity	Ground Reference
		VDC	Adjustment Range	Amps Continuous		
IPS 48-11	11 / 5.5	54.4	40 - 60 VDC	11	40 Amps	5 A-H Positive
IPS 24-22	11 / 5.5	27.2	20 - 30VDC	22	40 Amps	10 A-H Negative
IPS 12-40	11 / 5.5	13.6	10 - 15VDC	40	N/A	20 A-H Negative

Specifications

AC Input

Input Range (switch selectable): 115V = 92-130 VAC;
230V = 184-260 VAC
Frequency: 47-63 Hz

DC Output

Max. Load w/ External Rectifier and Battery Inputs: 40 A
Regulation: Line: $\pm 1\%$, Load: $\pm 2\%$
Ripple: $\pm 1\%$

Environmental

Temperature Rating: -10° to + 60° C; Derate linearly from 100% load @ 50° C to 75% @ 60° C

Internal Batteries

Type: 12 Volt, 5 A-H Sealed Lead-Acid, Maintenance-Free
Approvals: UL Recognized, DOT and IATA, approved for shipment by air

MODEL	Internal Battery Constant Current Performance (Amps) to 1.75 VPC				
	5 MIN.	15 MIN.	30 MIN.	1 HR.	2 HRS.
IPS 48-11	15.0	8.0	5.0	3.0	2.0
IPS 24-22	30.0	16.0	10.0	6.0	4.0
IPS 12-40	40.0	32.0	20.0	12.0	8.0



Powering the Network

Site Power System

The Site Power System (SPS) series provides a complete DC power solution that integrates quickly with batteries, loads, and monitors. Available in 12, 24 and -48 volt, 300 watt configurations, the compact assembly contains: power supply with temperature compensated, automatic boost/float battery charge cycle, low voltage disconnect, and programmable alarm contacts. High operating temperature rating with convection cooling make the unit ideal for remote site shelters, railroad wayside bungalows, and pole mount enclosure applications, as well as private network base stations and microwave sites.



Features

- Well regulated noise free output - no interference with sensitive electronic loads
- Separate Battery Charger output with remote temperature compensation sensor (provided)
- Automatic Boost Voltage output after AC power failure quickly recovers battery
- Low Voltage Disconnect protects batteries from over discharge
- Output current indicator LEDs
- Wide temperature operating range (-40° to +70° C), convection cooled, meets AREMA standards
- Alarm contacts interface with remote monitoring systems

Models	Voltage Range	Voltage Adjustment Range	Output Amps	Dimensions (Inches)			Weight (Lbs.)
				H	W	D	
SPS 12-20	13.6V	11 - 15V	20				
SPS 24-10	27.2V	22 - 30V	10	1.75	17	11.5	8
SPS 48-6	54V	44 - 60V	6				

Specifications

AC Input

Nominal: 110/220V, 50/60Hz

Voltage Range: 100-275V AC (full power output),
85-100V AC (reduced power output)

Frequency Range: 45-66Hz

Power Factor/Efficiency: >0.99 (full load)/87%

Input Fuses: Fuses in phase & neutral

Maximum Input Current: 300W Models: 4A ,

Isolation

Input to Output: 4,200V DC

Input to Chassis: 3,500V DC (VDR to chassis removed.)

Output to Chassis: 2,100V DC

Environmental

Cooling: Convection cooled

Range: -40° to +70°C operating range; -10° to +60°
@ 100% load rating. derate to 20% load below -10° C
and above +60° C

Protection

Input Voltage: Automatic shutdown, restarts automatically when correct voltage restored.

Current Limit: Adjustable to 50-100% of maximum rated current

Over Temp: Automatic current turndown, backup shutdown protection

Polarity Reversal: Output fuse with crowbar diode

Over Voltage: Adjustable limit



DC-DC Converters

Communication sites require isolated DC Converters to provide excellent voltage regulation, low noise, and high efficiency voltage conversion. Reliability is vital under continuous duty operation and high ambient temperatures. All these aspects were incorporated in the design of our rackmount DC Converters.



These units accept a wide input range at 24 or 48 VDC nominal, positive or negative ground, and produce pure 12 or 24 volt power. The solid state circuitry is conservatively designed and semi-conductors are selected and tested to withstand 200% of normal operating power.

Output voltage is maintained within 1% for all line and load conditions and the output is well filtered, allowing use with sensitive transceivers and telecom equipment.

Features

- 48, 24 volt inputs; 12, 24 volt outputs; positive, negative or floating ground
- Input/Output chassis isolation – 250 VDC
- 400 watt output
- Rated for continuous duty at full load
- Excellent regulation under all line/load conditions
- Low ripple provides noise free output
- High efficiency – 87% typical
- Easily adapts to both 19" and 23" racks, center mount (6" from front)
- Output volt and ammeter
- Output voltage adjustment on front panel
- Low profile – occupies two RU (one RU space above and below recommended for cooling)

Model	Input		Output			Dimensions			Weight	
	Voltage (VDC)	Max. Amps	Voltage (VDC)	Output Adjustment	Amperage (Continuous)	H	W	D	Lbs	Kg.
48-12-30RM	40 - 60	12	13.6	12.6 - 14.5	30	3.5"	19"	8.9"	10	4.6
48-24-15RM	40 - 60	12	27.2	25.2 - 29.0	15	3.5"	19"	8.9"	10	4.6
24-12-30RM*	20 - 30	26	27.2	12.6 - 14.5	30	3.5"	19"	8.9"	10	4.6
24-48-8RM	20 - 30	26	54.4	50.4 - 58.0	8	3.5"	19"	8.9"	10	4.6

* Special order - contact factory for availability

Specifications

Performance

Regulation: 1% line/load

Ripple: +/- 1/2% peak-peak max.

Idle Current: 48V: <100 mA, 24V: 300 mA

Efficiency: 85% typical @ 50% load.

Operating Temperature: -20 to 50° C; Derate linearly from 100% @ 50° C to 50% @ 70° C

Isolation: 250 volts input-output-chassis

Mechanical

- Powder coated aluminum front panel, vinyl coated aluminum case
- Mounting brackets provided for 19" or 23" rackmount, center or front
- Easy access terminal blocks on back of unit, with protective cover
- Front panel switch guard provided
- Output voltage adjustment potentiometer recessed in front panel

Protection

- Input and Output circuit breaker
- Current limited/short circuit proof
- High/low input voltage shutdown
- Fail-safe components guard against output over-voltage condition
- Automatic high temperature power reduction starting at 65° C heat sink temp
- Automatic thermal shut down and recovery @ 80° C heat sink temp. (automatic reset @ 55° C heat sink temp.)
- Reverse polarity protection

Options

- Operation as battery charger and/or parallel redundant operation
- Output Failure Alarm Contacts; Form C



Powering the Network

Modular DC Converter System

Powers Loads, Charges and Monitors Back-Up Battery, Ideal for Wireless System Transmitter/Enclosure Applications

- Combines all system power functions: power supply, battery charger, UPS circuitry and status monitoring in ONE compact DIN rail mount unit
- Separate outputs for load and battery
- "Load priority" circuit ensures power is dedicated first to the load, with remainder then allocated to battery charging, thus preventing a discharged battery from impacting operation of critical loads.
- 3 step charging for rapid battery recovery, programmable for battery type, with optional temperature compensation sensor
- Battery automatically supports load anytime AC fails
- Low voltage disconnect protects battery from total discharge
- Automatic periodic battery health diagnosis
- High operating temperature range to 70° C
- Alarm contacts: AC fail, battery at risk
- Communication MODBUS (DIN-UPS-48-10)
- CE Approved

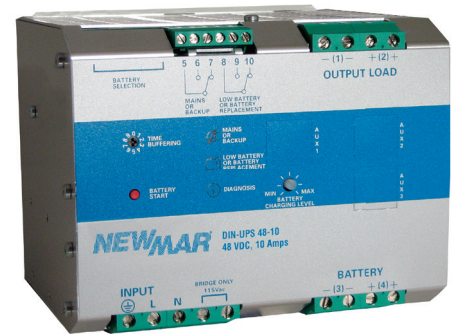

DIN-UPS 48-10

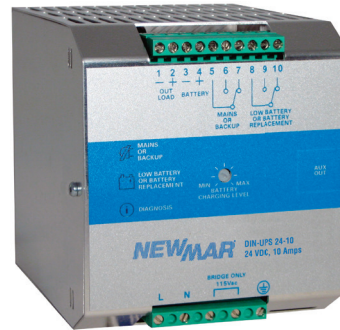

DIN-UPS 24-10



DIN-UPS 12-10

Specifications

Front Panel LED Indicators:

- Power Source: AC or on back up
- Battery and System Diagnostics (via blink code)

Settings/Selectors:

- Battery Type: AGM, Sealed Lead Acid, Gel-Cell
- Battery Charge Current Limit: 20 - 100% of charge amperage rating
- Back-Up Run Time on Batteries:
 - Programmed time limit: 1 - 60 min. (48-10 model only)
 - Or
 - Until LVD disconnect (all models)
- Power Restore Button: re-connects battery without AC present

Signal Outputs (form C):

- On backup power
- Battery abnormal condition (summary contact): Discharged, damaged, disconnected, sulfated/short circuit, reverse polarity, bad thermal sensor
- MODBUS Communication (DIN-UPS-48-10 only)

Temperature: -25 to +70° C. Continuous to 50°, de-rate 2.5% per° C >50° C (50% output @ +70° C)

Cooling: Free air, convection

Efficiency: 91%

Protection:

- Low Voltage disconnect at 1.5 volts per cell
- Internal fuse
- Current limiting
- Short circuit
- Reverse polarity
- Thermal overload shut down and recovery
- IP 20
- Designed to UL 1950

Terminal Blocks: Screw type

Mounting: DIN Rail Bracket (35mm)

Optional: Battery temperature compensation probe

Model	Input VAC	Output Voltage	Output Power	Dimensions (H x W x D)	Weight
DIN-UPS 12-10	115/230	12 VDC	10 Amps	4.5" x 2.6" x 5.3"	2 Lbs.
DIN-UPS 24-10	115/230	24 VDC	10 Amps	4.5" x 3.9" x 5.3"	2 Lbs.
DIN-UPS 48-10	115/230	48 VDC	10 Amps	4.5" x 5.9" x 5.3"	4 Lbs.



Powering the Network

Inverters



2RU, 24, 48 & 125V Input, 800 & 1600 Watts Output

- Pure sine wave AC output powers telecom equipment without performance decline
- Continuous duty rated - full output wattage maintained even during extended power outages
- Utility bypass, with fast load transfer switch, <4mS
- Form C alarm contacts and optional SNMP card for remote monitoring
- User-friendly Status and Diagnostic LCD/LED displays
- Remote Power Management optional via remote control relay RS-232 port

Model	DC Input		AC Output			Weight (lbs.)
	Voltage	Amps	Voltage	KVA	Watts	
24-1000RM	20 - 30	50	115 VAC, 60 Hz.	1 KVA	800	15.4
48-1000RM	40 - 60	25	115 VAC, 60 Hz.	1 KVA	800	15.4
48-1000IRM†	40 - 60	25	230 VAC, 50 Hz.*	1 KVA	800	15.4
48-2000RM	40 - 60	50	115 VAC, 60 Hz.	2 KVA	1600	17.6
48-2000IRM†	40 - 60	50	230 VAC, 50 Hz.*	2 KVA	1600	17.6
125-1000RM†	100 - 150	10	115 VAC, 60 Hz.	1 KVA	800	15.4
125-2000RM†	100 - 150	20	115 VAC, 60 Hz.	2 KVA	1600	17.6

* Adjustable for 60 Hz.; † Special Order - Contact Factory



1RU, 48V Input, 1000 Watts Output

- Pure sine wave AC output powers telecom equipment without performance degradation
- Continuous duty rated - full output wattage maintained even during extended power outages
- 1000 Watts - easily cascade for N+1 redundancy, providing maximum reliability required by data centers
- Utility bypass, with fast load transfer switch, <8mS
- Load & temperature controlled cooling fan
- Form C alarm contacts for monitoring abnormal conditions
- Fan aging, failure, disconnect and blockage alarm
- User-friendly Status and Diagnostic LCD/LED displays
- Remote Power Management optional via RS-232 port, summary alarm contacts for system fault

Model	DC Input	AC Output
48-1U-1000RM	36 - 60 VDC, 50A	115 VAC, 60 Hz., 1000 Watts



Powering the Network

Batteries

The BM Series Battery Module provides sealed, maintenance-free batteries in an easy to install rackmount shelf. Multiple modules may be paralleled for increased capacity.

Installing system back-up batteries or increasing current capacity has never been easier. The BM Series Battery Module, provides the complete solution in one low profile 2RU (3.75") chassis. No need for sourcing and installing battery trays, interconnect cable, terminals, lugs, battery breaker, etc. The BM provides it all in one package – sealed, maintenance-free batteries included – with easy input/output plug-in connectors on the chassis rear. Multiple modules may be paralleled for increased capacity.



The system comprises a rackmount Battery Shelf, model BMS and one or two 48 VDC Battery Modules, model BM. The shelf and modules are sold separately.

The battery modules slide easily into the shelf and are secured in place with a rear retaining pin and a front panel latch. Plug-in connector assemblies provided for quick connection to system load and/or paralleling multiple Battery Modules to meet run time requirements.

Features

- Battery Modules slide easily into shelf and plug quickly into DC power systems; shelf accommodates 2 Modules
- Modules and shelf fit together in low profile design – only 2RU (3.5")
- Internal batteries are sealed, maintenance-free and are IATA and DOT certified for shipment by air
- Plug-in polarized connector assemblies enable quick, easy, plug-and-play installation and eliminate the danger of reverse polarity connections
- Multiple BM/BMS systems may be paralleled for increased reserve capacity. Each module has two polarized connectors to allow for daisy chains
- 19" and 23" rack mounting brackets are provided for 6" forward mount configuration (3" relay rack rail required.)
- Battery on-line/off-line circuit breaker/switch controls output and provides overload protection

Model	Voltage		Reserve Capacity	Circuit Breaker Protection	Constant Current Performance (Amps) to 1.75 VPC				
	Nominal VDC	Float VDC			5 Min.	15 Min.	30 Min.	1 Hr.	2 Hrs.
BM-48-4	48	54.4	5 A/H	15 amp	15.0	8.0	5.0	3.0	2.0

Model	Description
BMS-19/23 Rackmount Shelf	Accommodates 1 or 2 Battery Modules

Specifications

BMS-19/23: Rackmount shelf accommodates 1 or 2 Battery Modules

Over-Current Protection: Circuit Breaker/ Switch (see matrix for value)

Output Connector Rating: 50 amps maximum (SB50)

Temperature Rating: -15° C to +50° C

Battery Type: Lead-Acid; Sealed, maintenance-free AGM. IATA and Dot certified for shipment by air.

Typical Battery Life: 3-5 years in standby use Internal Battery

Dimensions: Shelf: 3.5" H x 19/23" W x 18.2" D

Module: 3.4" h x 7.4" W x 18.8" D

Weight: Shelf: 20 Lbs.; **Module:** 19 Lbs.

Battery Strings

Communication and wireless network power systems typically require back-up power capacity at 8-10 hour rates or more. It's important that reserve battery systems in stand-by applications are sized properly and utilize high quality cells resulting in a long design life. Many factors must be considered when specifying and selecting the proper batteries for these applications, including peak and average loads, current, run time, ambient temperature, battery chemistry type, type, energy density, and desired re-charge interval.

Newmar can assist you in specifying your battery strings and supply the proper system for your application. Once we determine your needs, we can have the batteries delivered directly to your site, as part of a complete rackmount power system, a battery rack, or just the batteries themselves. Please contact us and we'll do the analysis for you and recommend a cost effective, reliable turnkey system.



Powering the Network

Circuit Breaker Distribution Panels



Circuit Breaker Distribution Panels



- High density, 2RU Rackmount Panels designed to accommodate virtually any 48, 24 or 12 VDC power distribution requirement
- Accommodates up to 10 or 20 circuits depending on model
- Distributes up to 900 amps (450 amps per bus)
- Unique plug-in circuit breaker design requires only front panel access for quick and easy installation
- Tripped breaker alarm contacts provide remote alarm/indications

- Circuit Breaker ratings: 5, 10, 15, 20, 25, 30, 40, 50, 75 or 100 amp
- UL Listed, CE Marked

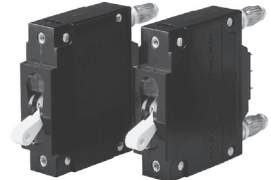

PBA Series Circuit Breaker

Models	Nominal Input/Output	Bus	Total Circuit Capacity	Total Current Capacity	Dimensions (Inches)			Weight* (Lbs.)
					H	W	D (w/ Cover)	
DST-10	12, 24 or 48 VDC	Single	10	450 amps	3.5	19	14.4	9
DST-20A	12, 24 or 48 VDC	Dual	20	900 amps	3.5	19	14.4	12

* Weight with no circuit breakers installed

This 8 position circuit distribution panel provides system integrators a flexible solution for DC power distribution on 12, 24 or 48 volt application. Plug in circuit breakers allow easy front access configuration to load distribution. Front panel indicators provide system status: Power available, and if breaker is tripped/off position. In addition, remote monitoring is provided via form C contact indicating tripped breaker condition. The panel's compact 2 RU height saves valuable rack space and the barrier terminal blocks on rear panel provide convenient wire terminals landing points, and simplifies cable management.



DC Power Distribution Panel Plug-In Circuit Breakers

Features

- 12, 24, or -48 VDC, Positive or Negative Ground operation
- Integrates easily with any power system
- 100 amps Bus - 8 plug-in circuit breaker capacity (breakers sold separately)
- Indicator LEDs: Power available, tripped/off circuit breaker
- Form C alarm contacts: tripped breaker, input fail

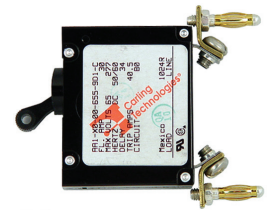

8 Plug-In Circuit Breaker Capacity
DST-FB Series Available
Ratings 5, 10, 15, 20, 35 or 30A

Models	Nominal Input/Output	Total Circuit Capacity	Total Current Capacity	Dimensions (Inches)			Weight* (Lbs.)
				H	W	D	
DST-100/8	12, 24 or 48 VDC	8	100 Amps	3.5	19	11	5

* Weight with no circuit breakers installed



Powering the Network

Fuse Distribution Panels



These fuse panels are ideal for DC distribution to low power loads in 24 and 48 volt positive and negative ground network applications and provide enhanced system reliability via dual input buses which allow configuration with redundant power sources. Each input bus accommodates 10 or 20 GMT output fuses (depending on model) in ratings up to 15 amps. Form C alarm contacts provide remote monitoring of input power and blown fuse conditions. Front panel LEDs indicates normal operation, fuse failure mode, as well as a user configured external alarm signal. Their low profile 1.75" (1 RU) occupies minimal space and can be configured for 19 or 23 inch rack mounting.

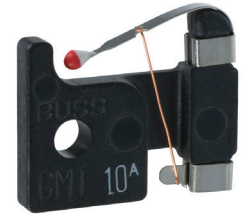

GMT Fuse
Available Ratings
1, 3, 5, 7.5, 10 and 15 Amps

Features

- GMT Fuse
- Polarity insensitive panels work with positive and negative ground systems +/- 24 or +/- 48 VDC
- Form "C" alarm contacts
- 1RU (1.75") in height will configure to 19" or 23" rack mounting

Models	Nominal Input/Output	Total Fuse Capacity	Amps per Bus (Dual Bus)	Total Current Capacity	Dimensions (Inches)			Weight (Lbs.)
					H	W	D	
FDP-1010	+/- 24 or 48 VDC	20	100	200 amps	1.75	17	11.5	8
FDP-2020	+/- 24 or 48 VDC	40	100	200 amps	1.75	17	11.5	8

Specifications

Nominal Input/Output: +/- 24 or +/- 48 VDC

Fuse Capacity

FDP 1010 - 10 GMT fuses per bus (20 total)
FDP 2020 - 20 GMT fuses per bus (40 total)

Total Current Capacity

FDP 1010: 200 amps (dual 100 amp bus)
FDP 2020: 200 amps (dual 100 amp bus)
Fuse Holder & Fuse Rating: 15 amps max.

GMT Fuses: Available amperages: 1, 3, 5, 7.5, 10, and 15. Other ratings available upon request. Note: Fuses sold separately

Operating Temperature: -20° to +60° C (-5° to + 140° F)

Alarms

- Form C alarm contacts for each bus
- External ground input alarm (bay or rack alarms)

Compliances: NEBS 3 certified

Mechanical

- Steel case painted flat black
- Mounting ears provided for 19" and 23" rackmount, flush mount or 6" offset
- 1 RU (1.75"), can be zero clearance mounted directly adjacent to other equipment

Front Panel Details

- LED status indicators:
 - Normal Operation
 - Fuse Alarm
 - External alarm
- Easy accessible fuse blocks
- Spare fuse holder

Rear Panel Details

- Input Terminal Block: Two 1/4" studs on 5/8" centers
- Output and Alarm Terminal Blocks:
 - FDP 1010: Barrier Terminal Block; #22 to #10 AWG wire for fork or ring #6 screw
 - FDP 2020: Elevator clamp style terminal block; #26 to #12 AWG wire.
- Cable Management Bar Clear Lexan cover protects wiring connections



Circuit Breaker Distribution with Remote Re-Boot Control



Instantly reboot, start or stop -48V telecom equipment in remote locations securely from your web browser or via program control. Eliminate overloads, brown-outs, blown breakers and other power problems before they occur, start devices in sequence automatically.

Ease of remote operation is made possible via numerous web browser control options of up to 8 breaker protected circuits. Remotely control power relays, choose from sequential on, all-off, selective circuit, or last state. In addition, an advanced custom control function is built-in, programmed via a BASIC style language that remotely initializes scripts without user intervention upon defined conditions such as: power-up, or when lock up is sensed via the "Auto-Ping" feature. Auto Ping continually monitors critical network devices, such as telecom equipment, servers and routers. If a device fails to respond after a user selectable number of pings, the power controller will automatically reboot it, or run a user's script with no user intervention. "Locked-up" devices are brought back to life instantly. Long distance service calls are averted.

Convenient monitoring via user-defined graphics and hyperlinks allow you to customize web pages. Programmable web links provide a seamless control panel of multiple systems comprising several distribution reboot units.

Features

- Remote control routers, telecom equipment. Switches any -48VDC device, up to 15 amps. An internal web server gives you manual control from anywhere in the world
- Use scripts to automate control from remote locations via LAN or WAN
- The "Auto-Ping" feature intelligently reboots a machine, router, server, or other Ethernet device automatically
- Windows utility provides e-mail notification of logs and events. Also supports UNIX style SYSLOG
- Front panel system control buttons with LCD display enables manual on-site relay control for ease of set-up
- Eight relays are individually controlled by scripts or web commands over Ethernet. Ethernet connection with static IP allows connection anywhere on your LAN or WAN
- Dual 50 Amp A/B input bus power four 15 Amp outputs for each bus, or wire inputs in parallel for an 8 circuit bus
- All inputs and outputs are circuit breaker protected; 15 amp. Other values available upon special request
- Universal 19" brackets accommodate center, back, or front rack mounting

Model	Input Voltage	Circuit Capacity	Dimensions (H x D x W)	Weight (Lbs.)
DST-8-RB	36 - 75V DC either A or B bus	8	1.75" x 11" x 17"	9.3

Electrical

Input: 36 - 75V DC, either A or B bus

Frequency: 20% ripple permissible

A/B Input Breakers: 50A thermal, manual reset

Power Dissipation: 10.3W Max (relays on) <3 W idle

Ethernet Interface: 10/100 autosensing, Static IP, TCP port selectable, 8 pin RJ-45 w/ internal FCC filtering

Input Terminal Rating: 100A

Relay Contact Rating: 20A DC

Password Transmission: Secure authentication Encrypted, base 64 Movable HTTP port for security

Output Circuit Breakers: 7, 10 or 15A thermal, manual reset

Power Fail Hold-Over: 600ms minimum (all relays on)

Switches & Controls: Reset to factory default switch Link, ACT (Relays On), Pwr LEDs

Power-Up Settings: Last relay settings, all relays off, sequential on or run PLC script

Software Controls (via web or script): Individual outlets on/off, all on

Environmental

Operating Temperature: -40° to 170° F, -34° to 77° C



Powering the Network

Site Power Monitor

Web-enable and integrate intelligence to any site's AC and DC power system for 24/7 monitoring, alarm condition notification, and data logging of vital electrical functions. All programmable, accessible, and managed via the Internet: TCP/IP or SNMP. View current conditions and log 30 day history of DC and AC power status at remote sites before dispatching personnel.

The Site Power Monitor is designed specifically for monitoring power supplies, rectifiers, batteries, converters, inverters, UPS, distribution panels, and AC power at communication sites, base stations, outdoor enclosures, and command vehicles via Ethernet or Wireless connection. The palm sized unit can be rack, DIN-rail, or wall mounted and is easily adapted to virtually any make of power system via nine sensor input ports which capture and stream critical data via the internet for analysis and logging of site history. Web page based programs are easily user configured for site parameters with up to 50 desired alarm conditions settings and multiple automatic notification options by e-mail, mobile phone and smart devices.

Sites without internet access can use the monitor solely as a data logger that captures and retains 30 days' data, ready for download to lap top for site history file and analysis of component performance and failure conditions.



Sensor Data

- DC Bus/Battery Voltage
- DC System Amperage/Battery Charge-Discharge Current
- AC Voltage
- Ambient Temperature
- Dry Contacts/Alarms

Firmware

- Programmable Alarms
- Data Logging
- Ethernet Camera

Optional Accessories

- Multi-Site Software allows simultaneous monitoring of up to 100 sites (model 100SS)
- Rackmount Panel (model SPM-RM)

Reporting Via

- Internet – Software Included
- E-Mail
- Mobile Phone

Monitor Inputs: 9 Total

DC: 3 Ports:

- 2 each: 0-40 VDC
- 1 each: 36-60 VDC
- Accuracy: +/- 2%

AC: 2 Ports:

- 120/240 (90-264) utility power (L-N or L-L)
- 120/240 inverter output (floating)
- Accuracy: +/-2%

DC Current: 1 Port

- +/- 100mv, 100 amp via differential using provided shunt
- Read battery charge/discharge current, or load current
- Accuracy: +/-3%

Dry Contact Switch Sensors: 3 Ports

- Possible uses: door open, water leak detection, smoke alarm, component fail, breaker trip, high temperature

Ambient Temperature Sensor

- Located outside case of unit
- Range: -40 to +60° C, -40° to +140° F
- Accuracy: +/-0.5° C



SPM-200 Installed into SPM-RM Rackmount Bracket

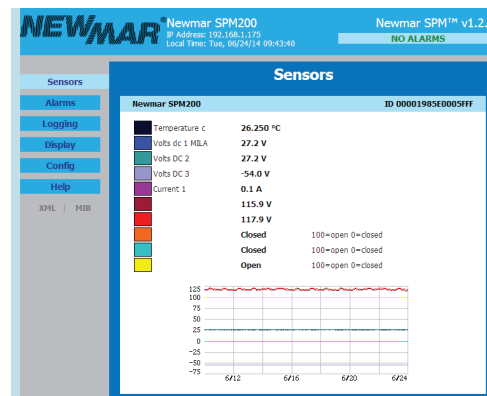

Sensors Webpage Screenshot

Model	Input	Dimensions (H x D x W)	Weight (Lbs.)
SPM-200	9 - 60 VDC, neg./pos. ground, 250 mA max.	3.27" x 4.66" x 2.18"	1



Powering the Network

Battery Disconnect Panels



BDP-1

- Provides over-current protection in high current battery wiring applications
- Provides a convenient means of disconnecting batteries from power plant during servicing
- High current single pole breaker is mounted into 2RU rackmount panel
- Auxiliary contacts (form C) provide tripped breaker

signal to power plant monitor

- 10,000 amp interrupt current rating (AIC)
- 19" rackmount ears provided (23" ears available, contact factory)
- Voltage Rating: 12, 24 or 48 VDC, positive or negative ground

Model	Battery Breakers	Available Amperage
BDP-1	1	50, 75, 100
BDP-2	2	50, 75, 100

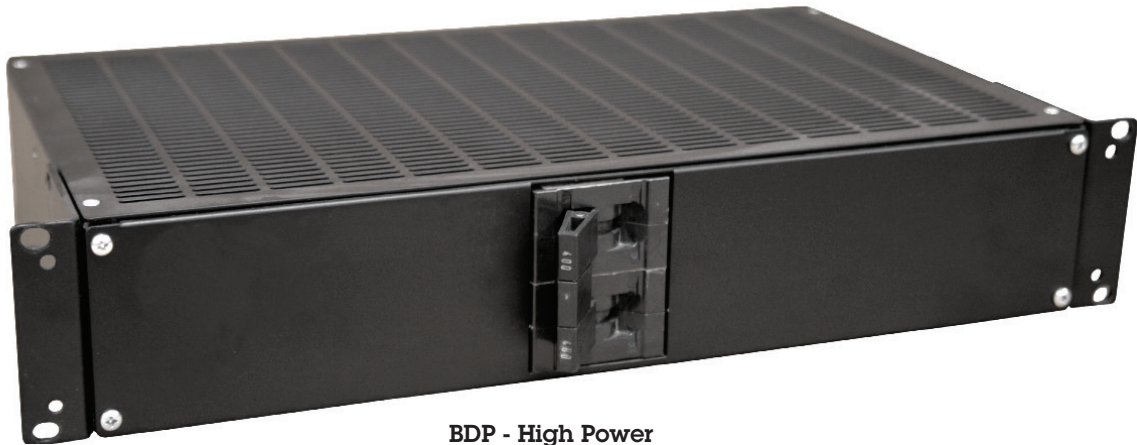

BDP - High Power

- Form C alarm contacts - breaker off or tripped
- Bus bar terminations, 1/4-20 tapped holes and hole center to center spacing for 2 hole lugs
- 25,000 amp interrupt current rating (AIC)
- 2RU chassis, adapts for 19" and 23" racks

- Voltage Rating: 12, 24 or 48 VDC, positive or negative ground systems
- UL and CSA listed
- Special order, contact factory for availability

Dimensions

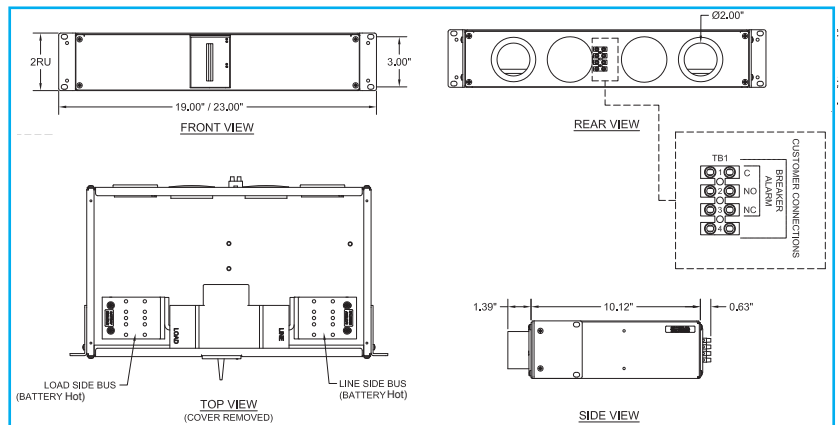

Model	Battery Breakers	Available Amperage
BDP-125	1	125
BDP-150	1	150
BDP-175	1	175
BDP-200	1	200
BDP-225	1	225
BDP-250	1	250
BDP-275	1	275
BPD-300	1	300
BDP-350	1	350
BDP-400	1	400

Low Voltage Disconnects/ Power Management

The **ULM-100** is a 1RU assembly that contains numerous DC control and monitoring features that integrate power and distribution components into a highly functional system. Built in features include:



Digital Battery Monitor and Alarm with Low Voltage Disconnect Integrates Rack Mount Rectifiers into a Fully Functional Power System.

low voltage disconnect, digital monitor of voltage and amperage, battery disconnect breaker, and alarm contacts. The digital display monitors bus voltage, battery voltage, system output current, and low voltage connect/disconnect set points. Alarm contacts actuate on low voltage and battery disconnect conditions. Rear panel bus bars provide ample terminal landings for easy integration with rack mount rectifiers, distribution panels and batteries.

Features

- Solid state (FET) low battery voltage disconnect with adjustable set points and manual over ride switch for system maintenance/testing, with adjustable low battery alarm contact alerting to impending system shutdown
- Digital monitor displays system bus voltage, battery voltage, total rectifier amperage, and connect/disconnect voltage set points, and system ambient temperature
- 100 amp battery disconnect breaker for system protection and easy testing and maintenance
- Form C alarm contacts
- All these functions in a compact 1 RU unit, minimizing system rack space
- For use with 12, 24, and -48V systems

Model	Voltage Range	Max. Continuous Current	Low Voltage Battery Disconnect	Size	Weight
ULM-100	8 - 65 VDC	100 Amps DC	100 Amp, Solid State (FET)	19/23", 1 RU	6.25 Lbs.

The **Power Function Manager (PFM-500)** is a system integrating component which converts ordinary power supplies (or Power Modules) into a fully integrated and multifunctional power system. The unit provides for control, monitoring, paralleling and protection of 12, 24 or 48 VDC, positive negative or floating ground power sources. A built-in Low Voltage Disconnect protects batteries in the event of extended AC power loss.



Features

- Low voltage battery disconnect protects batteries in the event of extended AC power loss
- Simplifies wiring with parallel tie point for power modules
- 12, 24 or 48 VDC input/output
- Digital meter displays: system bus voltage, battery voltage, total rectifier amperage, connect/disconnect voltage set points, and system ambient temperature
- Up to five isolated distribution circuit breaker capacity with alarm contacts; easy front panel plug-in installation
- Alarm LED (summary) indicates impending LVD disconnection, Power Module output fail or load circuit breaker trip
- Summary alarm contacts (form C) allow remote monitoring of system status
- Manual battery disconnect switch allows service/replacement of batteries without system shutdown

Model	Voltage Range	Max. Continuous Current	Low Voltage Battery Disconnect	Size	Weight
PFM-500	8 - 65 VDC	500 Amps DC	500 Amp, Contactor	19/23", 2 RU	20 Lbs.



Powering the Network

Accessories

Battery Trays and Equipment Shelves

Model	Tray Area	Weight Capacity	Colors	Ship Weight
T 19" x 19"	17.25" x 19.04"	350 lbs	Black	12 lbs
T 19" x 21"	17.25" x 22.3"	400 lbs	Black or Gray	17 lbs

23" tray available in various depths - contact factory for more information

Model	Shelf Area	Weight Capacity	Colors	Ship Weight
S 19" x 16" Adjustable	17.56" x 16"	200 lbs	Black or Gray	10 lbs
S 19" x 20" Adjustable	17.56" x 20"	200 lbs	Black or Gray	11 lbs
S 19" x 16" Ventilated	17.5" x 14.87"	150 lbs	Black or Gray	10 lbs



Battery Tray



Adjustable Equipment Shelf

Bus Bars

BBA-800

- 800 amp rated nickel-plated copper bus bar for use as heavy duty DC positive or negative connection point in rack installations
- Multiple attachment holes in two sizes provided for single and dual hole lugs: 18 ea. @ .312" x .500"; 6 ea. @ .437" round; 4 ea. @ .281" round

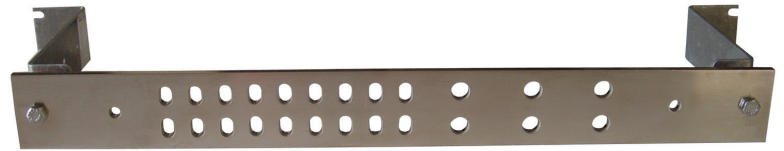

BBA-800

GB-19

- Copper bus bar for (unplated), 100 amp rating
- 14 ea. 1/4" landing points
- Installer must supply insulating stand-offs
- Tie bar provided for connecting to adjacent racks



GB-19

Model	Rating	Dimensions (H x W x D)	Weight
BBA-800	800 Amps	19.5" x 2" x 0.25"	4 Lbs.
GB-19	100 Amps	19.3" x 0.75" x 0.15"	1 Lbs.

Quick Connects

Designed specifically for use with Newmar's PM Series Power Modules and Power Function Manager in stacked rack configuration.

Models	Description	AWG	Weight
QCK-3	for up to 3 Power Modules, 70A rating	6	3 Lbs.
QCK-3A*	for up to 3 Power Modules, 80A rating	4	3 Lbs.
QCK-6	for up to 6 Power Modules, 70A rating	6	4 Lbs.
QCK-6A*	for up to 6 Power Modules, 80A rating	4	4 Lbs.
CCK-4**	for up to 4 Power Modules (2200 Watt)	4	6 Lbs.

* PM-12-80 - only use QCK-3A or QCK-6A; ** PM-48-50 - only use CCK



Rack Covers

Clear plastic panels attach to rear of racks to protect service personnel by preventing accidental contact with "live" terminals, etc., from top, sides and rear.

Model	Rack Height (1RU = 1.75")	Rack Width	Weight
RRC-3-19	3 RU	19"	4 Lbs.
RRC-7-19	7 RU	19"	5 Lbs.
RRC-3-23	3 RU	23"	5 Lbs.
RRC-7-23	7 RU	23"	6 Lbs.

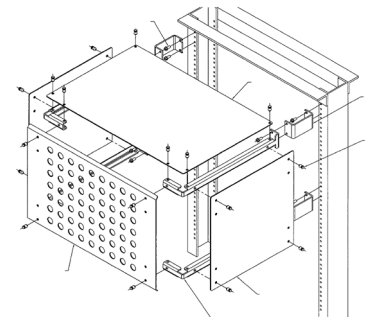

Powering the Network



NEWSTAR®

Powering The Network



- iDAS/oDAS
- Small Cell
- Microwave Backbone
- SCADA
- Utility Telecom
- Smart Grid
- WIFI
- Transportation
- Dispatch
- Healthcare
- 911 Call Center
- Wireless PBX
- Repeaters
- Cellular
- Data Centers
- Public Safety
- Trunking Systems
- Security
- Wireless ISP
- Microwave Backhaul
- Broadband
- Positive Train Control
- Private Networks
- Oil and Gas
- LAN
- Meter Reading
- Base Stations
- DC UPS
- Mesh Radio Networks



Powering The Network

Description	Pages	Description	Pages
Power Systems	1 - 9	Distribution	14 - 15
DC Converters	10	Remote Re-Boot	16
DIN-Rail	11	Remote Monitoring	17
Inverters	12	Battery Disconnects	18
Batteries	13	LVD & Power Management	19
		Accessories	20

www.poweringthenetwork.com



P.O. Box 1306 Newport Beach, CA 92663
2911 W. Garry Ave, Santa Ana, CA 92704
Phone: 714-751-0488 ■ Fax: 714-957-1621
E-Mail: sales@newmarpower.com

Distributed By:

